

## **NOTICE INVITING TENDER (NIT)**

**TENDER NOTICE NO: CDFD/ENGG/ELECT & HVAC/WORKS/2025-26/05**

Sealed Tenders are invited on behalf of the Director, CDFD from the working contractors of CPWD, Railways, MES, State PWD, State R&B, GHMC in respect of the work as detailed below up to 15.00 Hours on 06.03.2025.

1. **Details of Tender:**

1.	Estimated cost	Rs.1,77,49,923/-
2.	Earnest Money Deposit	Rs.3,50,000/-
3.	Tender Document Fee	Rs.5,000/-
4.	Completion period	150 Days
5.	Pre-Bid Meeting Date	27-02-2025 @ 11:00 AM
6.	Tender Opening Date	06.03.2025 @ 3:30 AM

2. **Name of work:** “SITC of 300TR Chiller, Chilled water ring main, chilled water connectivity from main Lab building chiller Plant to EAF facility and its associated material and works” at CDFD Campus, site ‘A’ Uppal, Hyderabad.
3. The Tender document can be downloaded from the website [www.cdfd.org.in](http://www.cdfd.org.in) and [www.eprocure.gov.in](http://www.eprocure.gov.in). The cost of tender document and EMD should be submitted along with requisite DDs drawn in favour of “DIRECTOR, CDFD” in the Office of Executive Engineer, Laboratory Building, Uppal Campus. Copy of Firm Registration Certificate, along with GST certificate should be enclosed. Cost of tender document and EMD to be submitted in the form of Demand Drafts separately. Amendments / Corrigendum, if any, would be hosted on the CDFD website only.
5. Tender Form is not transferable and the cost of tender form is not refundable.
6. The site of the work is located at Opposite to RTA Office, Uppal-Nagole Road, Uppal, Hyderabad.
7. The above Tender will be dealt with under “Two Bid System” i.e. the tenderers have to submit Technical Bid and Price Bid separately.

8. The Technical Bid shall contain the following:
  - (i) Tender Cost and EMD in the form of Demand Draft.
  - (ii) The Earnest Money Deposit mentioned against the above work shall be furnished in the form of Demand Draft in favour of “Director, CDFD, Hyderabad” from any nationalized Bank.
  - (iii) Work experience giving details of work done by the tenderer in the past Five years as per the Proforma – I and Proforma – II.
  - (iii) Other Information / documents as indicated in Instructions to Tenderers.
  - (iv) Any other information, tenderer may like to submit reflecting their credentials.
9. The Price Bid shall contain the following:
  - (i) Duly filled in Price Bid document.
10. Method of submission of Sealed tenders – Technical Bid envelope and Price Bid envelope both kept in one envelope super-scribed “SITC of 300TR Chiller, Chilled water ring main, chilled water connectivity from main Lab building chiller Plant to EAF facility and its associated material and works” at CDFD Campus, site ‘A’ Uppal, Hyderabad.
11. The tender has to be submitted in sealed cover with Tender Document comprising N.I.T, Letter of submitting the tender, General conditions of contract, Special conditions of contract and Price Bid Document.
12. Tenderer shall quote rates both in figures and words. He shall also work out the amount for each item of work and write in both figures and words. On check, if there is any difference between the rates quoted by the tenderers in the words and figures are in the amount worked out by them / him, the following procedure shall be followed.
  - (a) When there is a difference between the rates in figures and the words, the rates which correspond to the amounts worked out by the tenderer shall taken as correct.
  - (b) When the amount of an item is not worked out by the tenderer or it doesn't correspond with the rate written either in figure or in words, the rate quoted by tenderer shall be taken as correct.
  - (c) When the rates quoted by the tenderer in figures and in words tally but the amount are not worked out correctly. The rates quoted by the tenderer shall be taken as correct and not the amount.
  - (d) Except writing the rates and amount, the tenderer should not write any conditions or make any changes, additions, alterations and any modifications in the printed form of tender. Tenderers who are desirous to offer rebate, the same should be brought out separately in the covering letter and submit along with the tender.

13. Eligibility Criteria:

To be eligible for award of contract, bidders shall provide evidence satisfactory to the CDFD of their eligibility and of their capability and adequacy of resources to carry out the contract effectively as detailed below:

- i) Copies of original documents defining the constitution or legal status, place of registration and principal places of business of the company or firm or partnership.
- ii) Tenderer should submit the Copies of works executed previously with CPWD, Railways, Hospitals, Biotech Institutions, MES, State PWD, State R&B, Electricity Boards and any Private Limited Companies.
- iii) Certificate of Registration for Goods Services Tax (GST).

14. Earnest Money Deposit (EMD):

- i) The EMD mentioned against the above work shall be furnished in the form of Demand Draft in favour of “The Director, CDFD, Hyderabad” from any Nationalized Bank. The EMD of unsuccessful Tenderer shall be returned after evaluation of Tender.
- ii) Tenders received without EMD and Tender cost will not be considered. No request for exemption in payment of EMD will be considered.
- iii) The EMD amount will be forfeited if the successful tenderer fails to sign/execute the formal agreement within one week from the date of such intimation or fails to commence the work as per the work order.

15. CDFD does not bind itself to accept the lowest or any other tender and reserves the authority to reject any or all tenders without assigning any reason. All the tenders, in which any of the prescribed conditions are not fulfilled or incomplete, in any respect, are liable to be rejected.

16. This Notice Inviting Tender shall form the part of the Contract Document.

17. The Contracting firm should visit the site (CDFD) before quoting their Bid document.

18. The Director, CDFD reserves the right to postpone the tender issue date, submission / opening date and to accept or reject any or all tenders without assigning any reasons.

19. Tender completed in all respects shall be submitted as per the instructions given in the “Notice Inviting Tender” forming part of the tender document.

20. The tenderer shall sign all the pages of the tender documents and other documents submitted by him along with the tender.

21. The tenderer should ensure that amounts quoted should appear only in the price schedule document and nowhere else, otherwise, the tender is liable to be rejected.
22. Director, CDFD reserves the right of accepting the whole or part of any tender and tenderer shall be bound to perform the same at the rate or amount quoted.
23. The General conditions of contract of CPWD (GCC 2014) with all amendments shall be applicable and form part of agreement.
24. All works shall be executed confirming to CPWD specifications 2009.
25. The rates shall be quoted inclusive of all taxes except GST and GST rate shall be quoted separately in the price bid for complete item work as such noting extra shall be payable. Necessary Income tax shall be deducted as per rules in force.
26. Time is essence of the contract. In order to complete the work within the schedule time the tenderer is required to submit a detailed programme chart for various activities.
27. The tenderer must visit various electrical equipment's / line / site and get acquainted with the scope of work before quoting in the bid. The tenderer should submit the Site Visit Certificate which was issued by Executive Engineer (Ph.No:9441490598) (Every Thursday at 3:00 pm with prior appointment). Without submission of the signed copy of the Executive Engineer, the tender will be summarily rejected.



**CENTRE FOR DNA FINGERPRINTING AND DIAGNOSTICS,  
UPPAL, HYDERABAD**

**TENDER DOCUMENT**

**NIT NO: CDFD/ENGG/ELECT & HVAC/WORKS/2025-26/05**

**DATED: 13<sup>th</sup> February 2025**

**FOR**

**SITE 'A', CDFD CAMPUS, INNER RING ROAD, UPPAL,  
HYDERABAD -500039,  
INDIA.**

**PROJECT: -**

**“SITC OF 300TR CHILLER, CHILLED WATER RING MAIN, CHILLED WATER CONNECTIVITY FROM MAIN LAB BUILDING CHILLER PLANT TO EAF FACILITY AND ITS ASSOCIATED MATERIALS AND WORKS AT CDFD CAMPUS, SITE 'A' UPPAL, HYDERABAD”.**

**CLIENT: -**



**CENTRE FOR DNA FINGERPRINTING  
AND DIAGNOSTICS.**

**MEP CONSULTANT: -**



**HYDERABAD CONSULTING ENGINEERS**

**CONTENTS**

<b>Sl. No.</b>	<b>Description</b>	<b>Page Nos.</b>
	<b><u>TECHNICAL BID</u></b>	
1	Annexure I - Notice Inviting Tender	3 - 3
2	Annexure II- Instructions To Bidders (ITB)	4 – 10
3	Annexure III - Forwarding Letter	11 – 12
4	Annexure IV - Articles of Agreement	13 – 14
5	Annexure V - Compliance to Labour Laws	15 – 15
6	Annexure VI - Special Conditions of Contract	16 – 33
7	Annexure VII - Concept & Description	34 – 35
8	Annexure VIII - Technical Specifications	36 - 57
9	Annexure X – Drawings	
10	Annexure XI - General Check List	
	<b><u>PRICE BID</u></b>	
11	Annexure XII - Bill of Quantities	

**ANNEXURE I****NOTICE INVITING TENDER (NIT)****TENDER NOTICE NO: CDFD/ENGG/ELECT & HVAC/WORKS/2025-26/ 05**

Sealed Tenders are invited on behalf of the Director, CDFD from the working contractors of CPWD, Railways, MES, State PWD, State R&B, GHMC in respect of the work as detailed below up to 15.00 Hours on 06.03.2025.

“SITC OF 300TR CHILLER, CHILLED WATER RING MAIN, CHILLED WATER CONNECTIVITY FROM MAIN LAB BUILDING CHILLER PLANT TO EAF FACILITY AND ITS ASSOCIATED MATERIALS AND WORKS” AT CDFD CAMPUS, SITE ‘A’ UPPAL, HYDERABAD.

**1. Details of Tender:**

1.	Estimated cost	Rs 1,77,49,923/-
2.	Earnest Money Deposit	Rs 3,50,000/-
3.	Completion period	150 Days
4.	Cost of tender documents	Rs 5,000/- (Rupees Five Thousand only)

2. The Tender document can be downloaded from the website [www.cdfd.org.in](http://www.cdfd.org.in) and [www.eprocure.gov.in](http://www.eprocure.gov.in). The cost of tender document and EMD to be submitted in the form of Demand Draft drawn from any nationalized bank favoring “THE DIRECTOR, CDFD, Hyderabad”.
3. Tender Form is not transferable, and the cost of tender form is not refundable.
4. The site of the work is located at Opposite to Uppal RTA Office, Inner Ring Road, Uppal, Hyderabad - 500039.

**ANNEXURE II****INSTRUCTIONS TO BIDDERS (ITB)**

- 1.** The Technical Bid shall contain the following:
  - (i) Duly signed Technical Tender Document Comprising NIT, ITB, and Letter of submitting the tender, special conditions of contract, Drawings and Approved make's list.
  - (ii) Tender Cost and EMD in the form of demand draft.
  - (iii) Documentary evidence for Eligibility as per eligibility criteria.
  - (iv) Other Information / documents as indicated in NIT.
  - (v) Any other information, tenderer may like to submit reflecting their credentials.
  
- 2.** The price schedule shall contain the duly filled in price schedule.

Tenderer shall quote rates both in figures and words. He shall also work out the amount for each item of work and write in both figures and words. On check, if there is any difference between the rates quoted by the tenderers in the words and figures are in the amount worked out by them / him, the following procedure shall be followed.

- (a) When there is a difference between the rates in figures and the words, the rates which correspond to the amounts worked out by the tenderer shall take as correct.
- (b) When the amount of an item is not worked out by the tenderer or it doesn't correspond with the rate written either in figure or in words, the rate quoted by tenderer shall be taken as correct.
- (c) When the rates quoted by the tenders in figures and in words tally but the amount are not worked out correctly. The rates quoted by the tenderer shall be taken as correct and not the amount.



- (d) Except writing the rates and amount, the tenderer should not write any conditions or make any changes, additions, alterations and any modifications to the printed form of tender. Tenderers who are desirous to offer a rebate, the same should be brought out separately in the covering letter and submit along with the tender.

**3. Method of submission of Tender:**

The tender must be submitted in three cover system as follows:

- A. First Sealed cover shall contain the Technical Bid and EMD amount and duly Super scribed “Technical Bid for Providing “SITC of 300TR Chiller, Chilled Water Ring Main, Chilled Water connectivity from Main Lab building Chiller Plant to EAF facility and its associated materials and works”, Site ‘A’UPPAL, Hyderabad”.
- B. Second sealed cover shall contain the duly filled and signed Price bid duly super scribed Providing “SITC of 300TR Chiller, Chilled Water Ring Main, Chilled Water connectivity from Main Lab building Chiller Plant to EAF facility and its associated materials and works at CDFD Campus, Site ‘A’UPPAL, Hyderabad.
- C. The third sealed cover shall contain both the two covers indicated at (a) and (b) above and duly Super scribed “SITC of 300TR Chiller, Chilled Water Ring Main, Chilled Water connectivity from Main Lab building Chiller Plant to EAF facility and its associated materials and works at CDFD Campus, Site ‘A’UPPAL, Hyderabad.
- D. Sealed tenders are to be deposited in the Box kept for this purpose in the Executive Engineer Office, Inner Ring Road, Uppal, Hyderabad-500 039.

**4. Eligibility Criteria:**

The bidder shall meet the following eligibility criteria and submit the documentary evidence in the Technical Bid. The bid received without documentary evidence shall summarily be rejected.

- 4.1 Tenderer should have valid registration with CPWD/ Railways/ MES/State PWD/ State R&D/ Central & State Government Autonomous Bodies / Hospitals/ Biotech Lab (in business as Contractor for similar works for a minimum period of five years at the time of bid opening) and submit the copies of the same.
- 4.2 Project completion timelines are the essence for the project so the tenderer should provide satisfactory evidence to the CDFD to assess their eligibility, capability and adequacy of resources to execute the contract works effectively as per timelines.

- 4.3 The contractor should have experience of Government: State / Central R&D Laboratories and should have the experience in retrofit works at operational R&D Laboratories and should have the experience in retrofit works at operational R&D laboratories.
- 4.4 The Firm should have Registered in PF/ESI Office. The Firm should have registered office in Hyderabad.
- 4.5 The tenderer should have a minimum of 20 workers in their attendance register. The firm should have registered in PF and EPF offices
- 4.6 Copies of original documents defining the constitution or legal status, place of registration and principal places of business of the company or firm or partnership.
- 4.7 The Tenderer should be Hyderabad based with local GST registration.
- 4.8 Actual Proof of Annual Turnover: The bidder should have achieved a minimum annual financial turnover of Rs.400.00 Lakhs in any one of the last three years and solvency certificate from any nationalized bank for minimum Rs.20.00 Lakhs. The proof of annual turnover shall be duly certified by chartered Accountant / Income Tax Authorities.
- 4.9 The tenderer should submit the details of such completed works. In support of having completed these works, the tenderer should submit copies of the completion certificates from the owner companies indicating the name of work, the description of work done by the tenderer, value of contract executed by the bidder, date of start, date of completion (contractual and actual), value of the material supplied by the client.
- 4.10 Tenders containing two packets namely technical bid and Price bid shall be submitted within the due date.
- 4.11 The Financial / Price Bid of bidders who qualify Technical Bid only shall be opened later which shall be intimated to all eligible bidders participating in the Technical Bid. The tenderer should submit the Site Visit Certificate which was issued by Executive Engineer. Without submission of the signed Visit Certificate copy of the Executive Engineer, the tender will be summarily rejected.
- 4.12 The tenderer must visit various electrical works for HVAC / line / site and get acquainted with the scope of work before quoting in the bid. The tenderer should submit the site visit certificate which was issued by executive engineer, without submission of the signed visit certificate copy of the executive engineer, the tender will be summarily rejected.
- 4.13 The successful bidder shall submit a detailed micro-level plan of carrying out the job within a period of 5 days after award of work.

4.14 Copies of attested IT returns submission for the last five financial years.

4.15 **Work Experience:** The tenderer should have satisfactorily completed in the last five years in his own / firm name at least one similar nature of work cost not less than of **₹140.00 Lakhs** (Excluding GST) or two similar works of each cost not less than **₹100.00 Lakhs** (Excluding GST) or three similar works costing not less than **₹70.00 lakhs** (Excluding GST) during the last 5 (Five) years prior to the date of submission of the bid in any Central / State Government or Central / State Government autonomous bodies / Hospitals / Biotech Labs. Similar nature of work means the work of carrying out Electrical and/or HVAC Retrofit project or related works.

4.16 As the project works should be carried out in plant shutdown, time is most essence of the project, Tenderer should be acquainted to site conditions and should submit following inputs invariably to the Consultant/Executive Engineer-CDFD, same to be discussed with Consultant / Executive Engineer to build confidence on works execution prior to submit his tender for works.

- a) Detailed execution plan i.e., PERT/ CPM schedule and discussion on each activity.
- b) List of equipment used to do the work i.e., Crane, Hydra, Tripod & any other scientific method of handling equipment during lifting, shifting and inter connection.
- c) Equipment riggers, agency name & their field experience in handling heavy equipment.
- d) List of skilled/ semi-skilled/ un-skilled manpower engaging for work for each shift.
- e) Deployment of manpower in 3 shifts.
- f) Number of Managers & Engineers should depute for shift work.
  - g) Site Manager or site-in charge name, his experience, CV/ Resume and he should have minimum 15 years' experience in handling similar kind of works All above details and MOMs shall be part of tender document. No deviation / No amendments shall be accepted after awarding project on them. If any deviation is found during works execution, the decision of consultant/Executive Engineer is final whether to impose penalty alone or penalty & blacklist the tenderer for future works.

4.17 Certificate of Registration for Goods and Services Tax (GST) and the firm should have registered in MSME.

## 5. Earnest Money Deposit (EMD):

5.1 The EMD mentioned against the above work shall be furnished in the form of Demand Draft in favor of "The Director, CDFD, Hyderabad" from any Nationalized Bank. The EMD of unsuccessful Tenderer shall be returned after evaluation of Technical Bid.

- 5.2 Tenders received without EMD amount will not be considered. No request for exemption in payment of EMD will be considered.
  - 5.3 The firms registered with NSIC / MSME, if any, are exempted from payment of EMD and tender cost subject to submission of valid documentary proof.
  - 5.4 The EMD amount will be forfeited if the successful tenderer fails to sign/execute the formal agreement within one week from the date of such intimation or fails to commence the work as per the work order.
  - 5.5 The EMD of successful Tenderer shall be returned after receiving the Performance Guarantee.
6. **Performance Guarantee:** The successful tenderer must submit a performance guarantee for an amount of 5% of his / their tendered amount in the form of a bank guarantee. This performance guarantee will be returned to the contractor along with the final bill after satisfactory completion of the work, providing the work has been carried out in accordance with the agreement provision and the same is not forfeited for any reason.
  7. **Security Deposit:** 5% of the total value of the work done will be withheld as security deposit. The recovery on this account will be made from the running bills and final bill. The security deposit recovered will be released after successful completion of defects liability period (DLP).
  8. **Defect Liability Period:** Six months from the date of completion of work.
  9. **Compensation for delay in execution:** The contractor shall pay as compensation an amount of equivalent to 1% (one percent) per week on the total value of unfinished / uncompleted work, subject to a maximum 5% of the tendered value of work, as compensation / penalty amount to the CDFD.
  10. CDFD does not bind itself to accept the lowest or any other tender and reserves the authority to reject any or all tenders without assigning any reason. All the tenders, in which neither of the prescribed conditions are not fulfilled or incomplete, in any respect, are liable to be rejected.
  11. This Notice Inviting Tender (NIT) and instructions to Bidders (ITB) shall form part of the Contract Document.
  12. The Director, CDFD reserves the right to postpone the tender issue date, submission / opening date and to accept or reject any or all tenders without assigning any reasons.

- 13.** The successful tenderer on the acceptance of his tender by CDFD shall sign the formal contract within Seven days from the stipulated date of start of the work.
- 14.** The tenderer shall sign all the pages of the tender documents and other documents submitted by him along with the tender.
- 15.** The tenderer should ensure that amounts quoted should appear only in the price schedule document and nowhere else, otherwise, the tender is liable to be rejected.
- 16.** Director, CDFD reserves the right to accept the whole or part of any tender and the tenderer shall be bound to perform the same at the rate or amount quoted.
- 17.** The successful tenderer shall be required to execute an agreement with CDFD for carrying out the work as per the agreed conditions. The cost of stamp paper for the agreement shall be borne by the contractor as per the state stamp act.
- 18.** Diagrams shown in the document are indicative.
- 19.** The General conditions of the contract of CPWD (GCC 2020) with all amendments shall be applicable and form part of agreement.
- 20.** All works shall be executed confirming to CPWD specifications 2019 and tender specifications.
- 21.** The rates shall be quoted inclusive of all taxes and Cess except GST and GST rate shall be quoted separately in the price bid for complete item work as such nothing extra should be payable. Necessary Income tax and Labour Cess shall be deducted as per rules in force.
- 22.** Time is the essence of the contract. To complete the work within the scheduled time the tenderer is required to submit a detailed programming chart for various activities.
- 23.** Tenderers shall visit the site before quoting for better appreciation on work. For a site visit please contact Executive Engineer, (Mobile No: 9441490598) CDFD, Inner Ring Road, Uppal, Hyderabad - 500 039. Without submission of the signed Visit Certificate copy of the Executive Engineer, the tender will be summarily rejected.
- 24. Conditions of Contract:**
  - 24.1 PRICE:** The contract amount appearing in the priced schedule shall remain frozen during the entire tenure of the contract and no escalation in prices will be admissible on any account. However, whenever, the Minimum Wages, EPF or

ESI rates are revised by Government of India, payment will be made accordingly as per the revised rates.

- 24.2 **RISK OF LOSS:** Contractor shall guarantee the due safeguard and return of all owner's property including documents / materials issued to him and will be responsible for the full value thereof to be assumed by the owner for all loss thereof or damage thereto from whatever cause happening while in possession or control of the contractor, his servant's workman or agents

**ANNEXURE III**  
**FORWARDING LETTER**

To  
The Director,

CDFD Laboratory Complex, Inner Ring Road, Uppal,  
Hyderabad – 500039

(Hereinafter referred to as the Centre)

Dear Sir,

I/We have read and examined the following documents relating.....to the work“.....”.

- (a) Notice Inviting Tender
- (b) Instructions to Bidders (ITB)
- (c) Special Conditions of Contract
- (d) Technical Specifications
- (e) Drawings
- (f) List of Approved Makes
- (g) Bill of Quantities

Upon reading the terms and conditions contained or referred to therein and in accordance in all respect with the specifications design, drawings and other relevant details at the rates, I/We hereby tender for the execution of the works referred to in the aforesaid documents.

A sum of ₹ \_\_\_\_\_/- is hereby forwarded in crossed Bank Draft No: \_\_\_\_\_ dated \_\_\_\_\_ drawn on \_\_\_\_\_ Bank favoring \_\_\_\_\_ The Director, CDFD,

Hyderabad as Earnest Money Deposit. If I/We fail to keep the tender open for a period of 90 days, validity after opening the tender(s) or make any modifications in the terms and conditions of the tender, which are not acceptable to the Centre, I/We agree that the Centre shall, without prejudice to any other right or remedy, be at liberty to forfeit the said Earnest Money absolutely. Should this tender be accepted, I/We hereby agree to abide by and fulfil all the terms, conditions and provisions of the aforesaid documents.

If, after the tender is accepted, I/We fail to commence the execution of the works as provided in the conditions, I/We agree that the Centre shall without prejudice to any of their right or remedy, be at liberty to forfeit the said earnest money absolutely.

In the event of this Tender being accepted I/We agree to enter into an agreement as and when required and execute the contract according to your form of Agreement, within a month of receipt of work order, in default thereof, I/We do hereby bind my- self/ourselves to forfeit the aforesaid initial security deposit

I/We further agree to complete the work covered in the said schedule of quantities within 45 (Forty-Five) days reckoned from the tenth day of issue of letter of intent.

I/We agree to pay the Government, General Sales Tax (State and Central), Excise and Octroi duties, if any, Insurance, Seigniorage charges and all other taxes etc., at the rates prevailing from time to time as per the Act, as amended and rates quoted by me/us are inclusive of the same.

I/We agree to pay Income tax, to be deducted at source on the Gross value of the work done, and the rates quoted by me/we are inclusive of same.

I/We agree to get the work & workers to be engaged on the work at site and all materials and machinery collected and kept/operated at site for execution of the work. In case part work is taken over by the Employer before final completion of the whole work, such part may not be covered by the insurance from the date of taking over that part of work by the Employer. All the rates quoted by me/ us are inclusive of the same in full and nothing extra shall be claimed at any time on account of any of these.

Yours faithfully,

Contractor's Signature

Address:

Date:

.....  
.....  
.....  
.....  
.....



**ANNEXURE IV**  
**ARTICLES OF AGREEMENT**

This Contract Agreement made the ..... day of .....20...  
between

.....  
.....

.....(hereinafter called  
the “Employer”) on the one part and

.....

(hereinafter called “The Contractor”) on the other part, whereas the Employer is desirous of  
getting the work of

“.....  
.....  
.....  
.....”

executed and has caused drawings, ITB, conditions of contract, specifications and  
schedule of quantities etc., describing the works.

AND WHEREAS the SAID DRAWINGS numbered as per list attached inclusive of and  
the conditions of contract, specifications and schedule of quantities etc., have been signed  
by or on behalf of the parties hereto.

AND WHEREAS THE CONTRACTOR has agreed to execute upon and subject to the  
conditions set forth in the Schedule hereto (hereinafter referred to as “Said Conditions”) the  
works shown upon the said drawings and described in the same specifications and included  
in the said schedule of quantities for such sum as may be ascertained to be payable in terms  
of the Bills of Quantities, and which sum is estimated to be

₹.....  
(Rupees.....)

.....

(hereinafter referred to as “Said Contract Amount”).

**NOW IT IS HEREBY AGREED AS FOLLOWS:**

1. In consideration of the said sum to be paid at the times and in the manner set forthin the said conditions, the contractor shall upon and subject to the said conditions, execute and complete the work shown in the said drawings and described in the said specifications.
2. The Employer shall pay the contractor the said sum or such sums as shall bepayable hereunder at the times and in the manner specified in the said conditions.
3. Tender documents containing Notice to the Contractor, Conditions of Contract, Appendix thereto, Special Conditions of Contract, Specifications and Schedule of Quantities with the rates entered therein, shall be read and studied as forming partof this agreement and the parties hereto shall respectively abide by and submit themselves to the conditions and stipulations and perform the agreement on their part respectively in such conditions contained.
4. The contract is neither a fixed lumpsum contract or a piece work contract, but is a contract to carry out work in respect of the entire works to be paid for according to actual measured quantities, including variations from BOQ at the rates contained in the Schedule of rates and Probable bill of quantities or as provided in the said conditions
5. The Employer reserves for himself the right to alter the drawings and natures of the work, of adding/substitution to or omitting any items of work or having portions of the same carried out through alternate agencies without prejudice to this contract.
6. Time shall be considered as the essence of this agreement and the contractor hereby agrees to commence the work within 10 days reckoned from the date of issue of Letter of Intent to execute the work, as provided for in the said conditions and complete the entire work in subject to nevertheless to the provisions for extension of time.
7. This agreement and contract shall be deemed to have been made in Hyderabad and any questions or dispute rising out of or in any way connected with this Agreement and Contract shall be deemed to have arisen in Hyderabad and only the courts in Hyderabad shall have jurisdiction to determine the same.

AS WITNESS our hand this ..... day of ..... 20.....

Signed by the said in the presence of:

EMPLOYER

WITNESS :

NAME :

ADDRESS :

CONTRACTOR

WITNESS :

NAME :

ADDRESS :

**ANNEXURE V**

**COMPLIANCE TO LABOUR LAWS & APPRENTICE ACT**

The contractor shall comply with all the provisions of the Minimum Wages Act, 1948, Contract Labour (Regulation and Abolition) Act, 1970, and rules and orders framed there under and other labour laws affecting contract labour and Apprentice Act, 1961 and the rules and orders framed there under that may be in force or brought into force from time to time. Contractor shall obtain a valid license under Contract Labour (R&A) Act 1970 and Contract Labour (R&A) Central Rules 1971 before commencing work and which should be valid till the completion.

**ANNEXURE VI****SPECIAL CONDITIONS OF CONTRACT**

1. Before filling in the tender, the tenderer will have to check up all the tender documents and will have to get immediate clarifications from the CDFD on any point that he feels is vague or uncertain. No claim/damages or compensation will be entertained on this account.

2. **TENDERER TO VISIT SITE:**

Each tenderer must, before submitting his tender, visit the site of work, to ascertain the physical site conditions prices and availability and quality of materials according to specifications before submitting the quotations. No excuse regarding the non-availability of any materials or changes in the price will be entertained or extra allowed on that account.

The existing adjacent buildings belonging to Govt./private are in proximity of the proposed construction, hence the contractor shall cater for all arrangements to carry out the work without causing any disturbance to the occupants by providing screens with bamboo matting or other suitable material approved by CDFD. The contractor shall ensure that no dust or construction material falls near/around the existing buildings.

3. **EXECUTION OF WORK (PRICES TO INCLUDE):**

The whole of the work as described in the Contract (including the Bill of Quantities, the specifications and all drawings pertaining thereto) and as advised by the CDFD from time to time is to be carried out and completed in all its parts to the entire satisfaction of the CDFD. Any minor details of construction, which may not have been referred to in this contract, but which are usual in sound engineering & prevailing market standards and all construction practice and essential to the work, are deemed to be included in this contract. Rates quoted in the Price bid document shall be inclusive of all freights, taxes, such as octroi, Sales tax, Royalties, duties, excise, cess and seignories charges, turnover tax, sales tax on works contract, etc., as

well as transportation, so as to execute the contract as per the rules and regulations of Local Bodies, State Government and Government of India. Any increase in these taxes, during the pendency of contract, shall be borne by the contractor and no extra claim on this account will be entertained **except GST**.

The rates quoted in the tender should also include all charges for:

- a)
  1. Carrying
  2. Hauling
  3. Labour
  4. Fixing
  5. Watering
  6. Cleaning
  7. Making good.
  
- b) The contractor should arrange timely at his cost for all required.
  - i) Plant, machinery, scaffolding, formwork, ladders, ropes, nails, spikes, shuttering, temporary supports, platforms, tools, all materials etc., required for executing the work, and protecting them from weather and other normal/natural causes.
  - ii) Covering/protecting for the walling and other works, during inclement weather, strikes etc., as and when necessary and as directed.
  - iii) All temporary canvas covers/covering, lights, tarpaulin, barricades, water shoots etc.
  - iv) All stairs and steps, thresholds and any other requisite protection for the works.
  - v) All required temporary weather-proof sheds at such places and in a manner approved by the CDFD/for the storage and protection of materials, against the effects of sun and rain.
  - vi) All required temporary fences, lighting/signboards etc., guards, approaches and roads as may be necessary for execution of the contract works and for safe guarding the public.
  - vii) The whole of necessary plant and machinery like bull dozers, graders, road rollers, bitumen heating plants, blowers, pumps, concrete mixers, hoists, vibrators, scaffolding, formwork, tackle, cartage, labour etc., and removal of the same at the completion of works.
  
- c) The CDFD will be the sole judge in deciding as to the suitability or otherwise of the tools/formwork/machinery or plant that may be brought to the work site by the contractor for the proper execution of the work.
  
- d) The rates quoted by the tenderer in the Bill of Quantities items of work will be deemed to be for the finished work.

**4. BILL OF QUANTITIES (PRICE BID DOCUMENT):**

The Bill of Quantities forms part of the contract, but the Employer reserves the right to modify the same or any part thereof. The contractor shall not be allowed any compensation or damages for the work which is so omitted or cancelled or added or substituted by CDFD.

**5. ACCESS OF INSPECTION:**

The contractor is to always provide, during the progress of the works means of access with ladders, gangways etc., and the necessary attendants to move and adopt the same as directed for the inspection or measurement of the work by the Consultant/CDFD or any other agency employed by the Employer.

**6. DIMENSIONS:**

In all cases figured dimensions are to be accepted in preference to scaled sizes. Large scale details shall take precedence over small scale details/drawings. In case of any discrepancy, the contractor shall ask for clarification before proceeding with the work. Accordingly, if any work is executed without prior clarification, it is liable to be rejected and shall not be paid for,

**7. PROGRAMME OF WORKS:**

The contractor on starting the work shall furnish to the CDFD a PERT/CPM programmer, for carrying out the work stage by stage in the stipulated time, for the approval of CDFD and Employer, and follow strictly the approved time schedule by incorporating changes, if any, so authorized by the Consultant/CDFD and Employer, to ensure the completion of construction work in stipulated time. A graph or chart on individual items/group of items/trades of work shall be maintained, showing progress both in terms of quantities and value, week by week. The contractor shall submit to the CDFD a weekly progress report stating the number of skilled and unskilled labourers employed on the work, working hours done, quantity of cement, steel and other major items of materials (quantity and value wise) used and corresponding place, type and quantity of work done during the period.

The contractor must inform the CDFD 3 days in advance of the requirement of respective drawings and details by him, from time to time. The contractor shall strictly adhere to the approved programme and arrange for the materials and labour etc., accordingly.

Despite repeated instructions, if the contractor fails to show satisfactory progress of the work, the CDFD/may take suitable action as deemed fit, including levying of liquidated damages as per relevant clause of GCC of CPWD.

## **8. OFFICES, STORES, SHEDS ETC., ON THE SITE:**

- a. The contractor shall erect and maintain entirely at his own expense properly lighted, ventilated waterproof and lockable offices for his own staff on such parts as the CDFD shall indicate. Necessary permission from various authorities will be obtained by the contractor and necessary fees shall be paid by the contractor prior to constructing such offices, and as well for stores, huts for labourers or any other temporary structures required for the due execution of work. Any penalty levied by local authorities, for not following their bye-laws/regulations etc., in the matter, will be borne by the contractor. The contractor shall pay for the Electricity and Water charges consumed. All these offices shall be demolished, and the materials shall be taken away from site and ground left in good and proper order on completion of work, as required and directed.
- b. The contractor shall provide for all necessary storage on the site, in a specified area for all materials, in such a manner that all such materials, tools etc., shall be duly protected from damage by weather or any other cause. Stores for storage of cement shall all have weatherproof floors, walls and roofs and have proper locking arrangements and must be secure. All these must be maintained till the work is completed and so certified by the Consultant/ Executive engineer. Necessary and adequate watch and ward for all such accommodations and stores shall be provided for by the contractor at his cost and same included in the rates/amounts quoted by him. All such stores shall be cleared away and the ground left in good and proper order on completion of this contract unless otherwise expressly mentioned herein.
- c. All materials which are stored on the site such as cement, brick, metals and etc., shall be stacked in such a manner as to facilitate rapid and easy checking of quantities of such materials and prevent deterioration in quality due to water etc.

## **9 PROCUREMENT OF MATERIALS:**

The contractor shall procure all the materials including cement and steel required for the work from the open market. Time is the essence of the contract. Acceptance of the completion date by the contractor shall mean that he has taken into consideration the availability of all materials of approved make and quality in sufficient quantities at

respective markets/sources, to enable him to complete the entire work in the stipulated period.

Contractors will get samples of all materials approved by the CDFD, before placing order/purchase/procurement. They shall conform to relevant SI /B.I.S. codes and or tender specifications as applicable.

For all materials, the contractor shall quote for the best quality of the materials of best make/source or supply, and they should be got approved by the Consultant/ Executive engineer, before procurement.

In case sufficient quantities of approved quality materials from approved sources are not available in time, the contractor may have to procure the same from neighboring areas even with longer leads, as required and directed, at no extra cost. In case approved good quality sand is not available consistently throughout the duration of the contract period, best quality of sand locally available may have to be screened and washed, as directed by the CDFD depending upon the use of sand in different items of work, at no extra cost. The materials will be, however, as per relevant B.I.S. specifications as and wherever applicable.

#### **10. TESTING:**

The contractor shall, as and when directed by the CDFD, arrange to test materials and/or portions of the work at site in any approved laboratory at his own cost in accordance with the relevant specifications and BIS code of practice. The Consultant and Executive Engineer will visit the manufacturing site to test physically the materials/ equipment before dispatching the material / equipment at CDFD Site. The contractor shall transport all the materials from site to the approved laboratory at his own cost. The contractor shall carry out all the mandatory tests as per SI/ BIS relevant codes at the frequencies stated therein. Even after such tests, any materials brought to site or incorporated in the works are found to be defective or unsound or not as per approved samples, the contractor shall remove the same and re-erect at his own cost and without any additional time/period for the same, with reference to the date fixed for completing the work. In case these tests are not carried out at the frequencies stated, then proportionate costs of materials not so tested, including cost of testing and quantities of items of work executed with such materials, if otherwise accepted for retention in the work, will be deducted from the dues to the contractor. The deductions will be worked out by the Consultant/CDFD and shall be final and binding on him.

Tolerance on various material and items of work shall be allowed laid down in the documents below and the order of precedence shall be:

- a) Relevant SI / BIS Specifications.



- b) CPWD norms.
- c) Manufacturer's Specifications.

In the absence of the above CDFD decision based on the general practice being following shall be final.

#### **11. SITE MEETINGS:**

A senior representative of the contractor shall attend weekly meetings at works site and in additions, meetings as and when arranged by CDFD to discuss the progress of the work and sort out problems, if any, and ensure that the work is completed in the stipulated time.

#### **12. CUSTODY AND SECURITY OF MATERIALS:**

The contractor shall be responsible for the custody and security of all materials and equipment at site, and he will provide full time watchman/watchmen to look after his materials, stores, equipment's etc., including cement and steel at site and ensure that at no time unauthorized persons gains any access at works site.

#### **13. CEMENT:**

The Contractor shall procure cement from the authorized dealers only, after getting the make and quality approved by the CDFD. The brands shall be ACC/ Ultra Tech/ Birla Corp. Ltd. (Cement Division)/ JK Cement / Ramco or any other manufacturer as approved by CDFD. The contractor should purchase the cement in adequate quantity, sufficiently in advance, to have sufficient stock (not less than the requirement of the next fortnight) at site all the time. He will construct a cement storage shed of adequate capacity with watertight walls, floor, roof and secure locking arrangements and locking as required and directed. Empty bags will be contractor's property. Contractor's representative shall maintain cement account at site, showing cement received with details of invoices, etc., quantity used daily (with brief details of items/location of works on which used), and progressive consumption and balance at site. CDFD representatives will check this register periodically. Actual cement consumption will be periodically checked with theoretical cement consumption. Damaged cement will not be allowed to be used in work. The contractor will carry out transportation of cement, within the site, as and when required, at no extra cost.

#### **14. STEEL:**

The contractor shall procure steel from SAIL/TISCO/VSP/ JINDAL or any other manufacturer as approved by CDFD. The contractor shall produce the necessary

vouchers in support of the purchases and the manufacturer's test certificates, to confirm the quality. All wastages, rolling margins, site to site transportation shall be borne by the contractor. Contractor shall maintain at site, steel account showing – steel received at site (consignment wise and section wise) and steel used (section wise) for work corresponding to each of the bills, etc., which shall be subject to checking by CDFD. All scrap steel at site and unused steel at site to the extent not required on the work shall be contractor's property and contractor will be allowed to take it away after measurements/weight, and after getting necessary permission in writing from the CDFD. In case of any discrepancy between the actual quantity of steel lying at site and the balance quantity as per record, the decision of the CDFD shall be final and binding.

**15. MEASUREMENT TO BE RECORDED BEFORE WORK IS COVERED UP:**

The contractor shall take joint measurements with the consultant and CDFD before covering up hidden measurement or otherwise placing beyond the reach of measurement any item of work. Should the contractor neglect to do so, the same shall be uncovered at the contractor's expense or in default thereof, no payment or allowance shall be made for such work or the materials with which the same was executed.

**16. ACTION WHERE THERE IS NO SPECIFICATION:**

In case of any item/class of work, for which there is no specification mentioned (either in part or full), the same will be carried out in accordance with the relevant CPWD specifications (only for the specifications missing in the contract) and if not available even there (either in part or full) in, relevant standards of BIS/ SI shall be followed (only for the portions of specifications missing in the contract specifications and CPWD specifications). Bureau of Indian standard specifications, subject to the approval of the CDFD.

**17. CLEARING THE SITE ON COMPLETION/DETERMINATION OF WORKS:**

The contractor shall clear the site of the works as per the instructions of CDFD Executive Engineer. The site of works shall be cleared of all men, materials, sheds, huts etc., belonging to the contractor. The site shall be delivered in a clean and neat condition, as required by CDFD/within a period one week after the job is completed. In case of failure by the contractor, the CDFD, under advice to the CDFD/have the right to get the site cleared to his satisfaction at the risk and cost of the contractor.

**18. POSSESSION OF BUILDINGS/WORK COMPLETED:**

The contractor shall hand over to the CDFD possession of the completed works in stages, as and when required, and as directed by the CDFD.

The CDFD will take over the possession of completed works in stages and defects liability period will commence only from the date of handing over of all the completed works as stipulated in the price bid document.

**19. TYPOGRAPHIC, CLERICAL AND OTHER ERRORS:**

The CDFD clarification regarding partially omitted particulars or typographical, clerical and other errors shall be final and binding on the contractors.

**20. BENCHMARKS:**

The contractor shall construct and maintain proper benchmarks at different places on site as required and directed by the CDFD so that levels can be always checked accurately during the progress of work. In case benches are disturbed for any reason whatsoever, necessary rectification shall be carried out by the contractor at his cost as directed by the CDFD

**21. FORCE MAJEURE:**

Neither CDFD nor contractor shall be considered in default in performance of the obligations under this order if such performance is prevented or delayed by events such as but not limited to war hostilities, revolution, riots, civil commotion, strike, lock outs, conflagration, epidemics, accidents, fire, wind, floods, droughts, earth quakes or ordinances or any act of God, or for any other cause beyond the reasonable control of the party affected or prevented or delayed, is given within 30 (Thirty) days from the happening of the event and in case it is not possible to serve the notice within the shortest possible period without delay.

As soon as the cause of force majeure has been removed the party whose ability to perform its obligations has been affected shall notify the other of such cessation, the actual delay incurred in such affected activity adducing necessary evidence in support thereof. From the date of occurrence of a case of Force Majeure, obligations of the party affected shall be suspended during the continuance of any inability so caused with the cause itself and the inability resulting there from have been removed and the agreed time of completion of the respective obligations under this agreement shall stand extended by a period agreed to the period of delay occasioned by such events. Should one or both parties be prevented from fulfilling the contractual obligations by a state of Force majeure lasting for a period of six months or more,

the two parties shall consult each other and decide regarding the future execution of this agreement.

**22. COMPLETION OF WORK:**

The work shall be completed in 150 days and the start date of the work shall commence in 10 days from the date of issue of Letter of Acceptance of tender.

**23. BILLS OF PAYMENTS:**

The minimum value of work for interim payments shall be 3.0 lakhs. The contractor shall submit interim bills once in 10 days based on joint measurements recorded at site by the contractor's and consultant. All such interim payments shall not be considered as an admission of the due performance of the contract or any part thereof in any respect and shall not preclude the requiring of bad, unsound and imperfect or unskilled work to be removed and taken away and reconstructed or re-erected at contractor's cost, all as per CDFD instructions, and directions. However, the Executive Engineer-In charge may accept bills of lesser value at his discretion.

**24. WORKMANSHIP**

Quality of materials and workmanship shall conform strictly to specifications given/stipulated in the tender/contract, and contractor will ensure that the best quality of work will be done to the satisfaction of the CDFD, with strict control on the materials, workmanship and supervision.

**25. QUANTITIES:**

The quantities mentioned in the Bill of Quantities, included in the contract, are approximate and are subjected to variations as per actual site conditions & requirements and as directed by the CDFD. The work shall be executed and completed accordingly.

**26. SITE SUPERVISION:**

The contractor shall appoint at his own cost competent and adequate number of qualified Engineers at site, for

- (a) Joint measurements and preparations of bills.

- (b) For testing materials at site and in outside laboratory.
- (c) For concreting and reinforcement work.
- (d) For other general supervision. Their appointment shall be approved by the CDFD. The site engineers shall not be removed from the site without the written consent of the CDFD.

**27. TAX DEDUCTION AT SOURCE:**

Income tax, GST and Labour Cess shall be deducted at source as applicable, by CDFD from contractor's interim and final bill payments as required by law

**28. EXTRA / SUBSTITUTED ITEM RATES:**

Such items shall be executed as per directions/instructions of the Consultant/CDFD.

The work on extra/substituted items shall be started only after the receipt of a written order from CDFD. However, rates for additional/extra or substituted (altered) items of work, which are not covered in the contract shall be derived based on the relevant clauses of GCC, the finalization of which shall not hold up the execution of such additional/extra items in any manner.

**29. SERVICES DRAWINGS**

The contractor shall furnish completion drawings of all services in triplicate, showing the work as actually executed, along with levels. The costs of all these are deemed to have been included in the respective item rates quoted by the contractor and nothing extra shall be paid on account of any of these requirements/acts.

**30. AGREEMENT:**

The successful contractor shall be required to enter into an agreement within 7 days (Seven) from the date of issue of letter of acceptance. The contractor shall pay for all stamps and legal expenses incidental thereto. However, the written acceptance of the tender by CDFD will constitute a binding contract between CDFD and the contractor whose tender has been accepted, whether such formal agreement is or is not subsequently executed. The standard GCC of CPWD shall be part of the agreement.

### 31. INSURANCE:

The contractor shall provide insurance in respect of damage to persons and property and fire insurance as per relevant clause of General conditions of contract. In addition, he will also insure against riots and civil commotion. The insurance shall also cover third parties and all the people working on the site and visitors including contractors, workers, CDFD personnel, other contractors' workers etc. The contractor shall indemnify CDFD against any claim or compensation or mishaps of whatsoever nature at site during the progress of work.

The contractor shall prove to the CDFD from time to time that he/they have taken out all the insurance policies as required and directed and has paid the necessary premium for keeping the policies valid as per relevant clause of the General Conditions of Contract.

In case of failure by the Contractor or sub-contractor to effect and keep in force the insurance policies, then the client, without being bound to, may pay such premiums as may be necessary and deduct the same from any money due or which may become due to the contractor or recover the same as a debt due from the contractor.

- a) The contractor shall provide workmen compensation policy, obtained in his name.  
The below mentioned points should be covered in the Insurance Policy:
  - Bodily injury caused by accident during the course and scope of employment.
  - Bodily injury caused by disease or aggravated by the conditions of employment.
  - Death or temporary disablement.
  - Permanent total or partial disablement.
  - Legal costs and expenses incurred with the company's consent.
- b) Policies and certificates for insurance shall be delivered by the Contractor to the Owner for the Owner approval before the Date of Start of work i.e., date of execution of the contract. All such insurance shall provide for compensation to be payable in the types and proportions of currencies required to rectify the loss or damage incurred.
- c) If the Contractor does not provide any of the policies and certificates required, the Owner may incur the insurance which the Contractor should have provided and recover the premiums the Owner has paid, from the contractor bills. Otherwise, due to the Contractor or if no payment is due, the payment of the

premiums shall be a debt due. The cost of premium will be deducted from the contractor's bill, if at any time the work remains uninsured, irrespective of whether the policy is obtained by the owner.

- d) Alterations to the terms of the insurance shall not be made without the approval of the Owner or Consultants.
- e) Both parties shall comply with the conditions in the insurance policy.
- f) All policies in original shall be submitted to the owner before the release of the 1 st RA Bill. Particular attention is drawn to the following In case of accident, the Owner shall be informed in writing forthwith and First Aid, Hospitalization shall be provided by the Contractor. The contractor shall strictly follow regulations laid down by Govt. and State authorities in this regard and all cases are to be defended By the Contractor. The Owner shall not entertain any insurance claims. Compliance with all electricity regulations should be ensured.

### **32. EPF & ESIC:**

The contractor shall be required to maintain employment records as covered in relevant Acts and produce documentary evidence to the effect that he has discharged his obligations under the Employees Provident Fund Act 1952, and ESI Act, 1948, if applicable, Group Insurance and other Acts for the workmen working at site towards safety, statutory regulations and insurance aspects applicable as per latest government (central & state) acts.

CDFD reserves the right of imposition of penalty for non-performance or damage during emergency / routine work instructed to your mechanic / Engineers.

### **33. STATUTORY OBLIGATIONS:**

The contractor shall obtain a valid license under the Contract Labour (R&A) Act, 1970 and rules framed there under before the commencement of the work and continue to hold it till the completion of the contract.

The contractor shall maintain the following statutory registers as per the Contract Labour (Regulation and Abolition) Act 1970 and rules.

- a) Register of workmen.

- b) Employment cards of workmen.
- c) Master Roll Register.
- d) Register of Wages.
- e) Any other documents as required under the laws of the country.

**34. LABOUR LAWS AND RULES:**

The Site Engineer shall ensure that the contractor maintains relevant records and fulfils all conditions and requirements in accordance with

- a. The Payment of Minimum Wages Act
- b. Employer's Liability Act
- c. Workmen's Compensation Act
- d. Contract Labour (Regulations & Abolition) Act 1970 and Central Rules 1971.
- e. Apprentices Act 1961.
- f. Any other Act or enactment relating thereto and rules framed thereunder from time to time. The Site Engineer shall refrain from involving himself and the supervisors under him by comments/advice/attempts at mediation in any kind of labour dispute at site. His job is to report to his superiors any happenings of the sort in an objective manner.

**35. GOODS AND SERVICES TAX:**

Present GST is @ 18% on contract value and as applicable from time to time of GoI.

**36. WORKING AND SAFETY REGULATIONS:**

- a) The contractor shall observe all statutory, safety, and legal requirements / regulations issued by Central and State Governments applicable to the work as well as any local regulations applicable to the site.
- b) The contractor must fulfill the safety obligations at site and ensure that all safety equipment required for the execution of the work is available and used by the workmen at site.
- c) Required safety signage and other requirements as per safety norms must be compiled as per the instructions of the Owner/Consultant.



- d) A qualified person (i.e. shift in charge supervisor) is charge of safety should be at the site by the contractor to take care of the safety related issues during the execution period regarding workmen and material.
- e) The contractor shall be responsible for the provision of all safety notices safety equipment's including the safety gadgets for his workmen required by both the relevant legislation and such as the Owner may deem necessary. While working at heights, safety belts, nets, and safety helmets shall necessarily be used.

### **37. EMPLOYER CONTRACTOR:**

- 37.1 The contractor shall comply with the provisions of the payment of Wages Act, 1936, Minimum Wages Act 1948, Employment Liability Act 1938, Workmen's compensation Act 1923, Industrial Disputes Act 1947, Maternity Benefits 1961 and Contract Labour (Regulation and Abolition) Act, 1970 or the modifications thereof and other laws relating thereto and the rules made there under from time to time.
- 37.2 The contractor when required to employ more than twenty workmen on the works under this contract, shall be bound by the Contract Labour (Regulation and Abolition) Act 1970 and rules framed there under. No Contractor can undertake or execute his work without a license issued by a licensing officer.
- 37.3 Notice showing rate of wages, hours of work etc. shall be submitted to the Office of Labour enforcement officer and the same be displayed on the notice board in the establishment/laboratory.
- 37.4 The tenderer shall at all times comply with such rules and regulations as stipulated in relevant Factory Acts, Latest Indian Electricity Rules, Telangana State Electricity Rules, Indian Petroleum Acts, Indian Explosives Act, Fire Adviser, etc. the tenderer shall obtain the necessary clearance for operation and maintenance of the plant and equipment from the above statutory bodies wherever applicable.
- 37.5 The Director, CDFD, shall not be responsible for any injury or loss of any workers of the contractor / sub-contractor / vendor that may take place while on executing work defined under our scope of work as per this contract. Any compensation or expenditure towards treatment for such injury or loss of life shall be the sole responsibility of the contractor. The contractor is solely responsible for any damage Injury or accident that may occur to any of his personnel working under this contract. He will not claim any compensation from the Director, CDFD.

**38. FIRE PROTECTION / HIGH TENSION (ELECTRICAL)/ ELECTRICAL SHOCK:**

38.1 The contractor, his agents, representatives, workmen etc. shall strictly observe the orders pertaining to fire, HT / LT (ELECTRICAL) precautions prevailing within the restricted areas /electrical sub stations, etc.

38.2 The contractor, his agents, representatives, workmen etc. shall be strictly adhering to the fire/electric shock precautionary measures while working near the explosive areas/HT/LT./ ELECT.SUB STATION areas. During such times the workmen should be headed by their Engineer-in charge as a precautionary measure.

38.3 Contractor must abide by latest Contract Labour act, of Govt. of India/Telangana state as 1976 contract labour act is applicable.

38.4 The Contractor shall provide all safety appliances to his personnel at site like gloves, safety belt, gum boots, hard hats etc.

38.5 Any accident caused due to non – competence of safety rules, regulations and will entirely be the responsibility of the contractor.

38.6 Negligence/ malfunction of operator is noted which reflected in a monetary loss / material etc. should be recovered from the contractor RA bills & encashment of security B.G will be taken by depending by the nature of fault and how depth the operated/ supervisor is neglect/is responsible/ careless. The recoverable amount is decided by the Director, CDFD, which will be final and no correspondence or communication will be entertained from the contractor.

37.6 Specials tools and tackles, which are involved in the job to be brought by contractor only.

**39. INSPECTION BY THE CHIEF TECHNICAL EXAMINERS (VIGILANCE):**

The proposed work covered under this tender, during the progress and or after completion, can also be inspected by the Chief Technical Examiner/ Technical Examiner or Officers of the Central Vigilance Commission, Government of India, on behalf of CDFD to ascertain that the execution of the work has been done with materials and workmanship all as stipulated in the contract and as directed.

Contractor shall afford all reasonable facilities to the above vigilance staff and provide them with ladders, tapes, plumb bob, level etc., as required and directed and also necessary labourers skilled/unskilled to enable them to complete their

inspection/study/technical scrutiny and no extra shall be admissible to the contractor on this account.

**40. DEFECTS LIABILITY PERIOD:**

The Defects Liability period shall be six months from the date of handing over all the work completed in all respects.

**41. FINAL MEASUREMENTS:**

The period of final measurements shall be 15 days from the date of all works completed in all respects.

**42. WATER AND POWER SUPPLY:**

One water point and electrical point power will be made available by CDFD to the contractor for the work. The contractor should make his own arrangement for extending up to the work area.

**43. PRIORITY OF CONSTRUCTION:**

The Contractor must execute such items/works on a priority basis, as may be decided by the client. The work program is to be approved in writing before execution. Client reserves the right to alter the priority as the case may be.

**44. JURISDICTION OF COURT IN CASE OF DISPUTES:**

**This contract is under the jurisdiction of the court at Hyderabad.**

**45. QUALITY OF TENDERER'S SUPPLY ITEMS:**

All materials, fittings, fixtures shall be of heavy and high quality within the scope of specifications. Samples of materials like fittings of doors, windows, etc., should be approved within a week from the award of tender by the contractor from Consultant/CDFD.

**46. MODE OF MEASUREMENT:**

The mode of measurement will be as per CPWD standard specifications for all items. There shall be no disputes in this regard

**47. GENERAL**

These Special Conditions of Contract shall be read in conjunction with the CPWD General Conditions of Contract, CPWD Technical Specifications, and CPWD Technical Specifications for Electrical and air-conditioning works. Drawings and any other documents forming part of this contract wherever the context so requires.

The Notice Inviting Tender, ITB, Drawings & the bidding documents comprising of Special Conditions of Contract, Price Bid Document & Letter of Intent shall form part and parcel of the Agreement.

Notwithstanding, the sub-division of the documents into these separate sections and volumes, every part of each shall be deemed to be supplementary to and complementary of every other part and shall be read with and into the contract so far as it may be practicable to do so.

Where any portion of the General Conditions of Contract is repugnant to or at variance with any provisions of the Special Conditions of Contract, then, unless a different intention appears, the provisions of the Special Conditions of Contract shall be deemed to override the provisions of the General Conditions of Contract and shall to the extent of such repugnancy or variations prevail.

**48. OBSERVANCE OF LABOUR LAWS & PRINCIPAL EMPLOYER**

Observance of labour laws shall be as per clause No.19 of General Conditions of Contract. Principal Employer's certificate will be issued by CDFD.

**49. RATES ARE FIRM AND NO ESCALATION IS ALLOWED**

The Rates quoted by Contractor are firm and no escalation will be allowed on account of price increase of materials, fuel, labour etc. Clause 10C and clause 10CC of General Conditions of Contract are not applicable to this contract.

**50. MINIMUM REQUIRED T&P FOR WORK EXECUTION**

- a) Excavator cum loader LJCB 30 model or equivalent.
- b) Truck/Tipper/Dumpers/Load Tractors
- c) Water Tanker

**51. COMPLETION CERTIFICATE**

On completion of the installation a certificate shall be furnished by the contractor countersigned by the Consultant / Executive Engineer, under whose direct supervision the installation was carried out.

**52. TESTS AT SITE****GENERAL:**

The Contractor must perform all inspection and tests of the system as a whole and of components individually as required, under the supervision of the Experienced Engineer, in accordance with the provisions of the applicable ISI / BS / 'ASHRAE' standards or approved equal and as per site requirements. All tests shall be recorded in the format approved by the Department.

**ELECTRICAL EQUIPMENT:**

All electrical equipment shall be cleaned and adjusted at site before connection of power. The contractor, as per relevant IS/IE rules shall carry out the following minimum tests.

**1. Wire and Cable continuity tests:**

Insulation resistance test, phase to phase and phase to earth and phase to neutral on all circuits and equipment, using a 1000volt Megger. The earth resistance between conduit system and earth must not exceed half (0.5) OHM.

**2. The phase rotation tests.**

Operating tests on all protective relays to prove their correct operation before energizing the main equipment including secondary injection test at site. Operating tests on all starters, circuit breakers, etc.

**ANNEXURE - VII**  
**CONCEPT & DESCRIPTION**

**1. INTRODUCTION:**

- a) The Director, CDFD desires to “Retrofit Works for HVAC related Works for Chiller shifting, piping & SITC of New Chiller and its Associated Material & Works At CDFD Campus, Site ‘A’UPPAL, Hyderabad”.

In recent past heavy rainstorms / floods, the rain water was stagnated on the terrace floor of the Animal block. Along with rain water, the cooling towers spill over of water has corroded the structures for chiller & pumps and pipes.

Also, the water stagnated on the terrace floor has lead to seepage in the structures and damaging the same. The vibration of the running chillers is also causing disturbance to the structure.

To overcome these unforeseen eventualities and considering site constraints, planning to move the chillers and pumps to the ground floor level from existing location by providing civil masonry structure / MS super structure in designated locations and those shall be specified in enclosed schematic layout.

**2. PURPOSE OF PROVIDING INFRASTRUCTURE:**

- a. To protect the structure from further damage..
- b. To protect HVAC related equipment from stagnated flood water and ensure HVAC system uninterrupted operation.
- c. Reliability of the system.
- d. Provide aesthetically good, maintenance and operation friendly layout.

Retrofit works comprise of

**HVAC:**

1. Providing of suitable MS super structure to relocate the chillers and pumps.
2. Shifting and Lifting of Chilled water pipes connecting to main ring at main block.
3. Shifting and lifting of 100 Tr Chiller – 3 nos to ground floor location.
4. Pulling cables into inside panels and re-termination of cables.
5. Providing MS structure and chequered plate platform in front of panels for operation & maintenance purpose.
6. Commissioning and testing of Chiller along with Electrical starter panels.

**3. DESCRIPTION:**

To fulfil this requirement, the following civil masonry structure, MS super structure and retrofit works shall be envisaged:

- a. Civil masonry structure with RCC proposed for Chillers near main block. The same shall be made by digging of suitable size depth not less than 5 feet, excavating the soil, making footings with suitable size, cement concrete shall be reinforced with adequate dia. & quantity TMT steel rods, cement, sand and gravel mortar to bear heavy equipment static & dynamic loads.
- b. MS super structure proposed for all stationary chilled water pipes, electrical panels and associated stationary equipment installation. MS structure with chequered plate platform proposed for accessing equipment by service personnel. MS structure shall be made with adequate size MS 'C' channels, 'L' Angles, flat base plates, Chequered plates, MS pipes for railing and Anchor fasteners.
- c. Lifting and shifting of heavy equipment and associated ancillary equipment shall be carried out in safe manner by crane, hydra, tripod and other suitable and approved method along with competitive riggers.

## TECHNICAL SPECIFICATIONS

### A. HVAC

#### WATER COOLED CHILLERS

##### 1. WATER COOLED CENTRI CHILLER

Type of Chiller:	Water cooled Centrifugal chiller
Refrigerant:	R 134 A
Type of compressor:	Oil Free Dual stage Centrifugal
Tonnage of Refrigeration:	300TR @ Actual condition.

Chillers shall contain even pass condenser and cooler, cooler insulation, 24 G aluminum cladding for cooler insulation, adaptor box for terminating aluminum cables, flow switches, vibration isolation pads, and victaulic couplings.

Each unit shall be completely factory packaged including evaporator, condenser, and compressor with semi hermetic motor, refrigerant pipes and fittings, Microprocessor Control Panel, suction line and evaporator insulation, first charge of refrigerant gas, anti-vibration mounts etc. All the equipment shall be mounted on Galvanized iron or MS powder coated mounting Base plate fabricated out of channels, angles and other sections. The base plate shall be powder coated or hot dip galvanized. The chiller packages shall be suitable for indoor installation. The chiller shall be factory assembled and tested complete in all respect, painted prior to shipment. Unit should confirm to Indian / ASHRAE standard. The noise level of the chiller shall not exceed 72 dBA at 1m from the chiller or lower as specified for all loads including part loads.

##### 1.1 COMPRESSOR

The compressors shall be of Dual stage - semi-hermetic centrifugal type with inbuilt VFD powered by a high speed, direct drive electric motor. It shall be working on refrigerant HFC134a. The compressor shall be provided with phase loss, phase reversal, phase imbalance



and incorrect phase sequence apart from overload and under load protection. The impeller shall be of shrouded design and made of cast aluminum alloy of high strength and protected against corrosion. This shall be statically and dynamically balance and over speed tested so as to ensure vibration free operation. Impeller is designed for operation at speed higher than the drive motor, necessary speed increasing gear shall be connected to the impeller shaft in self aligning and balance way. Capacity control shall be by means of variable frequency drive and variable inlet guide vanes in the compressor suction to modulate the chiller capacity from 100 to 25 percent of full unit rated capacity without unstable compressor operation. The inlet guide vanes shall be electrically operated upon the actuation of temperature or pressure sensor.

Above 150TR, multiple compressor shall be proposed with independent circuits.

### 1.2 MOTOR:

The compressor motor shall be a hermetic, oil free, permanent magnet type directly coupled to the compressor. The motor will be bolted to a cast iron adapter plate mounted on the compressor to provide factory alignment of the shaft. The motor shaft shall be supported on active magnetic radial and thrust bearings. Magnetic bearing control shall be equipped with auto vibration reduction and balancing systems. Capacitor banks shall be inbuilt as a backup to the magnetic bearings designed for emergency touch down situations. During a power failure event, the magnetic bearings shall remain active throughout the compressor coast down. Motor stator and rotor shall be equipped with a pressure driven refrigerant cooling loop to maintain acceptable operating temperatures. Motor cooling shall be provided by an integrated liquid refrigerant injection system controlled by the compressor. Compressor shall start unloaded and current inrush shall be limited as low as 2 amps. Unit shall operate on 3-phase power at 400 volts +- 10%, 50Hz.

### 1.3 CONDENSER:

The evaporator shall be of shell and tube horizontal Flooded type with Mild steel shell and both sides finned copper tube copper tubes. The tubes shall have a minimum diameter of 19mm. Adequate number of properly spaced baffles shall be provided for maintaining optimum water velocity and heat transfer. Tubes shall be adequately supported. The condenser shall have a fouling factor of 0.00025 (in British units). The chiller shall be designed for a water side working pressure of 150 psig working pressure and tested at 1.3 times the working pressure.

Test certificates shall be produced for the chillers. The chiller shall be provided with victaulic connection for the water lines. Pressure drop shall be less than 25 feet water column.

#### 1.4 EVAPORATOR

The evaporator shall be of shell and tube horizontal Flooded type with Mild steel shell and both side finned copper tubes. The tubes shall have a minimum diameter of 19mm. Adequate number of properly spaced baffles shall be provided for maintaining optimum water velocity and heat transfer. Tubes shall be adequately supported. The evaporator shall have a fouling factor of 0.0001 (in British units). The evaporator shall be provided with solenoid valves for each refrigerant circuit, drain and vent valves, antifreeze thermostat fixed into water passage having direct contact with water, water pressure failure switch, pressure gauges and thermometers. The chiller shall be designed for a water side working pressure of 150 psig working pressure and tested at 1.3 times the working pressure. Test certificates shall be produced for the chillers. The chiller shall be factory insulated with 19 mm thick Nitrile rubber insulation after pressure testing. The chiller shall be provided with victaulic connection for the water lines. Pressure drop shall be less than 25 feet water column

#### 1.5 CONTROLS

The refrigerant flow control shall use an electronic expansion valve. The chiller shall have factory installed microprocessor control for various control functions. The control center shall have a 40 character alphanumeric Liquid Crystal display. The screen shall indicate entering and leaving chilled water temperatures, condenser entering air temperature, evaporating and condensing temperature of the refrigerant, motor current. Digital programming of various set points such as leaving chilled water temperature, percent current limit, pull down demand limiting, seven day time clock for starting and stopping.

All safeties shall be annunciated through alphanumeric display. The safeties shall include high condenser pressure, low evaporator pressure, high motor winding temperature, motor over current etc. The electrical panel shall have IP 54 protection suitable for mounting Al or Cu cable. The chiller shall be with RS485 or RS232 Port should be BMS compatible.

### 1.6 CHILLER PLANT MANAGER : (Optional)

The plant manager shall be able to compute the capacity and performance of chiller using the water flow, entering and leaving chilled water temperatures and entering condenser air temperatures and power consumed using the voltage, current, and power factor for various compressor loads. The results are to be logged in the form of a table. The capacity obtained and power consumed shall be compared with the performance charts for performance evaluation. The chiller shall have provision to integrate with 3rd party building automation system and shall be compatible with Bacnet or Modbus open protocols. Necessary Software, hardware, Field devices shall be included as a part of the plant manager in this regard with multiple level of operation with password protection. Cables required for connecting the chillers and other related ancillary equipment shall be quoted along with plant manager.

### 1.7 PERFORMANCE RATING:

Manufactures shall submit Computer generated rating chart for 100%, 75%, 50%, 25% load performance for Specified parameters and for ARI condition.

### 1.8 PERFORMANCE & WITNESS TEST:

Prior to shipment, chilling machines shall be subjected to inspection and witness of performance tests at Factory AHRI Test Bed by Owner's representative to verify various performance parameters as confirmed by vendor earlier at the time of award of contract. Performance test shall be carried out as per procedure laid down by ARI standards and as per job specified parameter at 100%, 75%, 50% & 25% loading. All expenses inclusive of business class airfare, boarding lodging etc. relating to the witness test will be borne by the vendor / contract.

### 1.9 SUBMITTALS

Provide the following in addition to the standard requirements with the Bid;

- ˘ GA Drawing
- ˘ Part Load Rating Chart for Site condition (both Relief and constant condenser entry) & ARI condition.
- ˘ Specification

˘ Installation standards

#### 1.10 APPLICABLE STANDARD:

˘ Chillers shall be rated and certified in accordance with AHRI Standard 550/590.

˘ Heat Exchangers are constructed in accordance with Section VIII D1 of ASME Boiler and Pressure Vessel Code.

1.11 BEE star rating compliance: Unit should meet 5 star rating;

#### 1.12 Optional Quote ( if required as per BOQ )

˘ ASME stamping if required

˘ Auto tube cleaning system

˘ 300psig pressure vessel

˘ Unloading, lifting, shifting of chiller.

˘ Active Harmonic Filter

### **PIPING, VALVES & ACCESSORIES**

#### **SCOPE:**

The scope of this section comprises the supply and lying of pipes, pipe fittings and valves, testing and balancing of all water piping required for the complete installation as shown on the drawings. All piping inclusive of fittings and valves shall follow the applicable Indian Standards.

#### **CHILLED WATER PIPING:**

All chilled water and condenser water pipes and fittings shall be of, MS class `C' (heavy class) conforming to BIS 1239 for pipe size upto 150mm dia and for pipe size 200mm dia and above shall be as per BIS 3589 having minimum 6mm thick-ness. All jointing in the pipe system shall generally be by welding, unless mentioned otherwise, or directed at site. All welding shall be done by qualified welders and shall strictly conform to Indian Standards code of procedure for manual metallic welding of Mild steel as per BIS 823. Condenser & Chilled water line must have quick filling connection

arrangement at plant room 40mm size with full way valve & a drain line too of the same size.

All pipes and their steel supports shall be thoroughly cleaned and given one primary coat of red oxide paint before being installed. All chilled water piping will rest on PUF blocks 48 Kg/cum density neatly molded or teak wooden block of 2 1/2" thickness with groove to the radius of pipes and seated on MS angles / channel. All welded piping shall be subjected to the approval at site.

Fittings shall be malleable casting of pressure rating suit-able for the piping system. Fittings used on welded piping shall be of the weld able type.

Tee-off connections shall be through equal or reducing tees, otherwise ferrules welded to the main pipe shall be used. Drilling and tapping of the walls of the main pipe shall not be resorted to.

Ball valve, Butterfly valves, globe valve, conforming to the following specifications, shall be provided as shown on drawings:

Pipe bends shall be prefabricated type up to 150mm dia. Pipe bends fabricated at site shall be provided with segments of bend not exceeding 15°angle. A 90° bend shall thus be provided with 6 Nos. welding joints. Pipes shall be cut with Power saw/Hacksaw only, followed by hand grinding to provide V-groove.

All chilled water piping and fitting shall be pressure tested, then insulated as described under the section "Insulation".

After all chilled water piping has been installed; the pressure testing shall be run for at least three days of eight hours each. The piping, fittings & supports shall be painted with one coat of red oxide paint & two finish coats of 3 mils each of approved color of synthetic enamel paint conforming to IS 2379 (Incase the chilled water piping, the paint shall be done after insulation of the pipes). The direction of flow of fluid in the pipes shall be visibly marked with identifying arrows.

#### **TESTING OF PIPING: -**

The CONTRACTOR shall hydrostatically test the entire piping system including valves and specialties for 10kg/crm<sup>2</sup> or 1.5 times the working pressure whichever is greater,

and the pipe should hold the pressure for 24hours. For hydrostatic testing and water flushing, the CONTRACTOR shall furnish necessary pumps, equipment and instruments, piping etc., The PURCHASER will provide water at available points of supply to which the CONTRACTOR's temporary piping will be connected. The cost of bare piping quoted inclusive of above testing equipment, spool piece, instruments etc., also.

### **BALL VALVES:**

The ball valve shall be of full-bore design. It shall have body of Forged brass / bronze. The ball and the shaft shall be of stainless steel / chrome plated. The seat shall be of PTFE. The valve shall be complete with socket weld ends. The valves shall be suitable for a working pressure of 16kg/cm<sup>2</sup>.

Size	Construction	Ends
15 to 40 mm	Gun metal	Screwed
50 mm and above	Body cast iron spindle and valve seat of Bronze or Gun metal or Nitrile rubber (In case of butterfly valve)	Flanged

All valves shall be heavy duty conforming to BIS 5155, BIS 5152, and BIS 780. Valves shall have non-rising spindles unless specified otherwise and shall be suitable for not less than 16 Kg. per sq.cm. Gauge working pressure.

### **BUTTERFLY VALVES:**

Butterfly valves shall be of slim seal, short wafer type with standard finish shall be suitable for mounting between flanges drilled to ANSI 125. The valve body shall be of cast iron / Ductile Iron. The disc shall be of quality ductile iron with epoxy coated finish or equivalent quality material. The disc shaft consists of SS-420 or equivalent material, pivot and driving stem. The disc shall move in bearings on both ends with 'O' Ring to prevent leakage. The seat shall be molded black EPDM / Nitrile rubber. The valve operation shall be with flow control lever and notches up to dia of 150mm and shall be with gear for 200mm and above. The body shall be short wafer type up to 150mm dia and shall be flanged / lugged type for the valve equal to and above 300mm dia. The valves shall be suitable for a working pressure of 16kg/cm<sup>2</sup>.

## **PRESSURE INDEPENDENT DYNAMIC BALANCING CUM CONTROL VALVE**

Pressure independent dynamic balancing cum control valve. The self-balancing dynamic flow control valves should be pressure independent, two way, modulating to accept digital or analogue input signals, the valves accept 2-10 VDC, 40 20 mA or digital 3 point floating or PWM input signal. Each valve should have an adjustable maximum flow rate setting to enable flow limitation and balancing to the coils or zones that the valves are controlling.

The actuators should be microprocessor based with a self-calibrating feature.

### **Valve Specifications:**

Static Pressure: 4000 KPa, 580 psid.

Media Temperature: - 20 ° C to 120° C.

Ambient temperature: - 10 ° C to 55° C

Body Material: Ductile Iron ASTM A 536 -65 T. Class 60 – 45-18

Internal Components: 316 Stainless Steel

Stem Seals: EPDM

Body Tapings: “ISO

Maximum Close Off Pressure: 700 kPa D, 101 psi

Maximum Operation Pressure  $\Delta p$ : 400kPaD, 58 psid.

### **Actuator Specification**

Supply voltage: 20-26 Voltage AC or 28 – 32 Volt DC

Power Consumptions: 10 VA

Frequency: 50 Hz

Control Input: 2 – 10 VDC / 4 – 20 mA / 3-point floating

: PWM control

Position Output: 2 -10 VDC / 4 – 20 mA

Turn Time: 150 Seconds (From close to Fully Open Valve)

### **Y-STRAINER:**

Strainers shall be of 'Y' type or pot strainers as shown on the drawings, with cast bodies designed for the test pressure specified for the butterfly valves. Strainers shall have bronze screen with 3mm perforations. Screen shall be removable and replaceable without disturbing of the main pipes. All strainers shall be provided with isolating valves at inlet to the strainer, so that the strainer may be cleaned without draining the system. Strainers shall be provided on the inlet side (at suction) of each pump / AHU / CSu / other as specified, and where shown on the drawings.

### **CERTIFICATE & MEASUREMENTS**

The CONTRACTOR shall furnish certificates of all the materials purchased by him and also complete instructions from the manufacturer regarding the storage, installation and application. The MEASUREMENT of Valves, Expansion tank, Air separator shall be measured as numbers. The measurement is inclusive all its accessories, actuator, companion flanges, GI bolts & nuts, gaskets, drain port, additional supports with primer & painting etc., as required. The cost also inclusive of insulation wherever it is used for the chilled water application and as per the BOQ. The cost of the valve & other items shall be inclusive of supply, storage, installation, testing, commissioning etc.,

### **TEMPERATURE GAUGE:**

Shall be dial type with centigrade & Fahrenheit scales Temperature gauge shall be of the separable socket type and shall have extended brass stem, where required, for insulated pipes. Temperature gauge shall be installed at water supply and return at air handling units, chillers & condensers as shown on the Drawings. Range of scales shall be 30-120 deg.F (0- 50 deg. C) for air conditioning applications.



**PRESSURE GAUGES:**

Shall be installed on suction and discharge of pumps, supply & return at air handling units, inlet and outlet at chillers, and condensers and cooling towers and included in Schedules of Quantities. Suction side gauges at pumps shall be compound gauges with 150 mm dia of the range 0-75cm. (0-30 inches) mercury vacuum and 0 - 4 Kg. per Sq.cm (0-60 psi) pressure. Discharge side gauges at pumps and at all other locations shall be 150 mm dia of the range 0.5 Kg. per sq.cm. (0-60 psi) pressure. Gauges shall be connected to the pipes by U-tube with gun metal gate valve, required for gauge protection during testing.

**AUTOMATIC AIR VENTS WITH BALL VALVE:-**

It should be of compact & efficient design made of Brass construction to efficiently remove air pockets from hydraulic systems with a maximum working pressure of 4-6 bars & working temperature of 120 deg C. The air vent shall be of 20mm dia. The air vents shall be provided with additional ball valves. The air vent shall relate to necessary Copper / GI tubes and left to the nearest waste drain point /pipe if they installed in the floor occupied areas.

**MANUAL BALANCING VALVES:**

The Manual balancing valves shall be double regulating, balancing and shut-off valve in open or closed hydronic heating/cooling system and Flanged in Cast iron for PN16, Ductile Iron for PN20, EPDM for Cast iron Construction, with special alloys, with drain cocks, With Pressure Test Cocks as per IS 778 – 1984

**PIPING INSTALLATION:**

Tender drawings indicate schematically the size and location of pipes. The contractor, on the award of the work, shall prepare detailed working drawings, showing the cross-section, longitudinal sections, details of fittings, locations of isolating and control valves, drain and air auto vent valves, and all pipe supports. He must keep in view the specific openings in buildings and other structures through which pipes are designed to pass.

Piping shall be properly supported on, or suspended from, stands, clamps, and hangers as specified and as required. The contractor shall adequately design all the brackets,

saddles, anchors, clamps and hangers, and be responsible for their structural sufficiency.

Pipe supports shall be of steel, adjustable for height and primer coated with rust preventive paint and finish coated black. Where pipe and clamps are of dissimilar materials, a gasket shall be provided in between spacing of pipe supports shall not exceed the following:

#### **SLAB SUSPENSION**

<b>Pipe Size</b>	<b>ROD Diameter (mm)</b>	<b>Base</b>
<b>Support</b>		
Up to 65mm	10	U Clamp
80 to 125mm	12	50 x 50 x 6 thk. Angle

Floor mounted support shall be preferred. And should refer to the drg and get approvals on support construction / design before fabrication and installation.

<b>Pipe Size</b>	<b>Spacing between supports</b>
Upto 12mm	1.5 meter
15 to 25mm	2.0 meter
30 to 150mm	2.0 meter

Auto/ Manual air vent valves shall be provided at all specified points in the piping system for air venting

#### **TESTING & BALANCING:**

All piping shall be tested to hydrostatic test pressure of at least two and half times the maximum operating pressure, but not less than 10 Kg per sq.cm. Gauge for a period of not less than 24 hours. All leaks and defects in joints revealed during the testing shall be rectified and gotten approved at site.

Piping repaired subsequent to the above pressure test shall be re-tested in the same manner. System may be tested in sections and such sections shall be securely capped, then retested for entire system.

The contractor shall give enough notice to all other agencies at site, of his intention to test a section or sections of piping and all testing shall be witnessed and recorded by Owner's site representative.

The Contractor shall make sure that proper noiseless circulation of fluid is achieved through all coils and other heat exchange equipment in the system concerned. In case of improper circulations, the contractor shall rectify the defective connections. He shall bear all expenses for carrying out the above rectifications. He shall bear all expenses for carrying out the above rectifications, including the tearing up and re-finishing of floors and walls as required.

The contractor shall provide all materials, tools, equipment, instruments, services and labor required to perform the test and to remove water resulting from cleaning and after testing.

After completion of the installation, all water system shall be adjusted and balanced to deliver the water quantities as specified, quoted or as directed, to individual air handling units and fan coil units cooling coil.

Water circuit shall be adjusted by balancing cocks provided for balancing; these shall be permanently marked after balancing is completed so that they can be restored to their correct positions, if disturbed.

Complete certified balancing report shall be submitted for evaluation and approval. Upon approval, four copies of the balancing report shall be submitted with complete drawings and documents.

Exposed Pipes & insulation surface/cladding shall be provided the approved color along with name & arrows marked distinctly in-service areas.

#### **CHILLED WATER PIPES INSULATIONS:**

Thermal insulation on the chilled water pipes shall be applied as follows:

<u>Pipe Size in mm</u>	<u>Thickness of Insulation in mm:</u>
------------------------	---------------------------------------

## 1) Chilled water pipes

15 to 80mm : Tubular section – Pls refer the BOQ for thickness details

100 and 125mm : Sheets – Pls refer the BOQ for thickness details

The insulation has to be covered and finished with 2 layers of fiber glass cloth with star bond & for Piping Running exposed / ceiling / exposed to ambient shall be finished with 24G Al. cladding over the nitrile rubber refer tender specs for details

2) GI / CPVC Drainpipe : 6mm

**Application:**

The pipe shall be thoroughly cleaned with a wire brush and rendered free from all rust and grease.

The pipes shall be treated with two coats of chloro sulphonated zinc chromate based anti-corrosive coating CRC. Apply one coat of heat resistant, polychloroprene base low VOC adhesive grade R242/SR998 on both surfaces with open time 10-25 minutes.

The insulation shall be fixed tightly to the surface taking care to seal all joints with 50mm wide and 3 mm thick self-adhesive insulating material (Nitrile rubber) (transverse and circumferential). Apply tack coat of insulation protective coating SB 30-36 evenly by brush @2 to 2.5 sqm/liter. After applying tack coat, embed the glass fiber or canvas cloth immediately and make it wrinkle free. Apply first coat of SB 30-36 on prepared surface @2 to 3 sqm/liter. Apply finish coat of SB 30-36 once first coat is fully cured @2 to 3 sqm/liter.

No broken insulation anywhere shall be permitted under any circumstances what so ever. If anywhere the quality of installation is found to be inadequate as per Specifications or as per the performance requirement, the installation shall have to be redone without any extra cost to the Client.

All valves, fittings, flanges, strainers etc. in the chilled water line shall be insulated in the same manner as described above for chilled/ hot and drain water pipes with uniformly cut pieces from slabs of expanded polystyrene. Care should be taken to

ensure that no damage would be caused to the insulation when valves or strainers are operated.

Ensure the specified sheet and tube thickness is maintained throughout the installation, Including all load support brackets and fittings.

PT slab marking need to be done above insulation with red color self advise tape of 75mm.

## **SAMPLE MOCK UP OF INSULATION OF ALL SURFACES TO BE APPROVED BEFORE WORK IS TAKEN UP**

### **1. BALANCING, TESTING AND COMMISSIONING**

#### **General**

All operational testing, adjusting, balancing, calibrating, setting to work and commissioning shall be carried out by the contractor.

The following instruments shall be required to be on site continuously during the testing period and balancing period.

Dry bulb thermometer ( $\frac{1}{2}$  °C accuracy), sling psychrometer, voltmeters with hot wire sensing element, air velocity meter, manometers for static pressure, pressure gauge set, ammeter, voltmeter, power factor meter, megger and tachometer.

All instruments shall be calibrated and have suitable scales (measured variable to the within  $\frac{1}{4}$  to  $\frac{3}{4}$  full scale reading).

All testing, re-adjusting or balancing as required shall be include in the lump sum bid. The Executive Engineer-CDFD shall advise when this final testing may be started. During the testing period, each trade shall have his superintending foremen and mechanics available to aid in testing and to perform any adjustment as directed. Test results shall be included in the operating and instruction manuals.

#### **Testing - General**

The contractor shall be responsible for all adjustment and balancing to have all systems performs in accordance with the drawings and Specification. Preliminary testing shall first be conducted as outlined to determine the preliminary adjustment and balancing.

In general, field testing of equipment is to be conducted in accordance with the best and latest ASME and I.E.E. practice.

Quantities indicated for flows or on outlets shall be within 5% of the specified or indicated quantities or as approved by the Executive Engineer-CDFD. The contractor shall allow for any necessary changing of pulleys in their lump sum bid.

The work shall be carried out under the direction of either a competent Professional Engineer or Qualified Technician.

The contractor shall be required to furnish and install separate sockets, tapings and tees required for testing. Gauges and thermometers shall be calibrated before test is conducted.

Results shall be tabulated on proper forms. These forms shall be submitted to the Executive Engineer-CDFD for approval before any work is started.

All controls shall be checked to ensure proper operation. Brackets and supports for sensing elements shall be checked for adequacy. Capillary sensors shall be protected.

### **Testing of Piping System**

All tanks, coils and similar equipment shall be factory tested with at least 50% higher than maximum operating pressure and test certificate shall be submitted to the Executive Engineer-CDFD.

All pipe, valve, fittings, etc. shall be tested to a hydrostatic pressure of double the working pressure, but in no case less than 10 bars, for a period of twenty four hours. Pipe shall not deform unduly during these tests and shall remain perfectly tight. Fittings and bends shall be examined after the test to make sure that no permanent deformation has occurred. Expansion conditions of all piping shall be carefully studied during the testing and any necessary changes in hanger, anchor or guide locations shall be made accordingly.

All joints and pipe shall be examined carefully for leaks, porous pipe or sand holes in fittings and shall be repaired, or replaced without caulking or rusting. All piping concealed under floors, in chases and partitions etc. shall be tested before same are furred in or insulated.

After the piping and coils are installed, the entire system shall be cleaned out by flushing. The flushing out shall continue for as long as required to thoroughly clean the systems. All strainers shall be cleaned out after piping is cleaned.

The flushing out of the systems shall be only be carried out by experienced staff, it shall be carried out methodically from top to bottom as defined in an approved schedule of procedure.

The schedule shall be based on the schematic drawings with clear indication of equipment, i.e. valves, coils, tubes, pumps, etc. which are sensitive to choking. Such

equipment shall be by-passed, isolated or completely removed from the system and the circuit completed.

The flushing velocity must exceed the design flow rated by between 200% and 300%. The flushing water shall be generated externally; the system pumps shall not be used. The system pumps must be by-passed, isolated or removed during flushing and the circuit completed.

The pipe work system shall be separated into sections; each should be incorporated a drain valve at its lowest point. The drain valve should be compatible with the main up to at least 50mm diameter with access to drainage.

After the final high velocity flush, the system shall be filled and a dispersant polymer added. This shall be circulated for an appropriate time and drained. The system shall be filled immediately from the bottom up. Filling shall be slow, taking care to remove air from extremities and high points. On no account shall the system or any part of the system be drained and left empty and wet for a significant time after cleaning.

The contractor shall furnish hydraulic pump, temporary connections, apparatus, material, fuel and labour required for the tests. After completion of the work, the contractor shall adjust all apparatus and parts of the system so that they will be in proper working order. All valves shall be properly packed on completion of the test.

All pumps shall be tested by taking pressure gauge readings, motor power consumption and speed and comparing them with factory test result curves. The motor starter heaters settings shall be recorded together with the voltage and amperage on each phase, and the power factor. All pumps shall operate so that there is no pipe borne noise, vibration, rattles etc.

The flow rate through all the piping system components shall be verified and adjusted until the proper temperature differentials are obtained at full load operation.

### **Testing of Air Conditioning System**

Each system shall be completely tested. The test shall include complete checking of the fans, readings of air quantities in the mains, branches and outlet etc. All temperatures required including outdoor, mixture air, before and after all coils, individual room or space temperatures, coolant temperatures, shall be recorded. Both wet and dry bulb temperature shall be measured. Test shall be conducted at conditions approaching design full load. All systems shall be subjected to a 72 hours operational test at approaching full load conditions, during which time readings are to be recorded continuously. During this period which shall be subject to the approval of the Executive Engineer-CDFD the design load conditions including fluctuations will be maintained.

**Operational Test and Demonstration**

When the entire system is ready for operation, a demonstration of the completeness of the installation shall be made by this contractor to the Owner's operating staff when and as directed by the Executive Engineer-CDFD.

During the demonstration, the contractor shall make all necessary adjustment to apparatus and shall instruct as completely as possible the Owner's operating staff when and as directed by the Executive Engineer-CDFD.

All testing shall be witnessed by or done under the direction of the Executive Engineer-CDFD before the system will be accepted. The contractor shall notify the Executive Engineer-CDFD in due time when he is ready for any testing.

**Reliability Test and Test Records**

When the demonstration tests have been completed successfully and the contractor has notified the Executive Engineer-CDFD that the installation is ready to work, each section of the installation will be required to operate continuously or intermittently as may be required without failure of any kind for a period of one calendar month before the "Handing-Over Certificate" will be issued.

Should any failure occur due to, or arising from, faulty fitting, materials or workmanship but otherwise sufficient to prevent the commercial use of the installation, the reliability test period of one calendar month shall be repeated after the contractor has remedied the cause of failure to the satisfaction of the Executive Engineer-CDFD.

At the completion of the installation, the contractor shall test the output from each diffuser, grille, fan equipment, etc. and submit copies of the Record of Tests similar to those attached to Executive Engineer-CDFD for approval.

**Maintenance and Operation**

The contractor shall be fully responsible for One year guarantee of all equipment and systems. The contractor shall include in his tender One year service and maintenance contract. He shall be required to inspect the job at least once a month at which time he shall read and log all gauges, thermometers, meters etc. He shall inspect all bearings, belt drives, coupling etc. He shall lubricate, clean and adjust all equipment and check safety controls. He shall furnish and install replacement parts. Filter and strainers shall be cleaned or replaced as required. Logs shall be submitted to the Owner's operating staff each month.



## 2. VIBRATION AND NOISE CONTROL

### General

The aim of this section is to describe the Vibration isolation systems and Noise Control treatments which shall be used to eliminate all objectionable noise and mechanical vibration in the installation of all mechanical installation.

All motor driven equipment shall be both statically and dynamically balanced and together with connecting pipe work and/or ductwork shall be suitably isolated in accordance with this specification.

All acoustic isolation requirements are specified in other section. It shall be the responsibility of the contractor to install and adjust all acoustic and vibration isolation equipment specified, shown on the drawings or as required to achieve the level of noise indicated.

All vibration isolation equipment shall be furnished by only one manufacturer/supplier who shall be responsible for the adjustment and testing of all isolators. All vibration isolation shall be guaranteed to attain the percentage isolation specified for the lowest disturbing frequency.

RPM	Maximum vibration vertical, Horizontal and Axial (mm)
0 - 300	0.13
301 - 500	0.10
501 - 1000	0.08
1001 and above	0.05

### Scope

Vibration isolation shall be obtained by installing spring type isolators, rubber and/or cork type isolators, and/or inertia bases where specified or where indicated on the drawings or as required to meet the recommended acceptable standard.

Vibration isolation shall be provided for the following:-

- a) All air handling units, motor and their inertia slabs, Hot Water Generators, Humidifiers.

- b) All chilled and hot water piping and suspended drain lines within all Mechanical Rooms and for a distance of 6 meters measured along the pipe from the point where the pipe leaves the room.
- c) All supply, return and exhaust fans, motors and their inertia slabs.
- d) All supply, return, relief, intake and exhaust air ducts within all Mechanical Rooms and for a distance of 6 meters measured along the duct from the point where the duct leaves the room.
- e) Acoustic isolation shall be obtained by installing silencers, acoustic duct lining and fan enclosures where specified.
- f) Flexible connections shall be installed as described in the Specification.
- g) The contractor shall submit installation drawings showing in details the proposed arrangement of vibration isolation to be installed chillers, fans, pumps, etc., the required isolators and with inertia bases where specified.

### **Prevention of Sound Transmission on Critical Areas**

Precautions shall be taken to ensure the openings through walls, floors etc. for the passage of piping, ductwork, conduit and the likes are properly sealed to prevent sound transmission.

Required openings shall not make larger than necessary. Care shall be taken to ensure that piping, ductwork, conduits and the like does not come in direct contact with the wall, floor, sleeves or other objects. After installation, the gap between all sleeves and piping, ductworks and conduit etc., shall be sealed with wood wool blanket or approved fire seal material, unless stated otherwise in the specification.

### **Testing**

All equipment and installation when complete, testing, balancing and commissioning shall be sound tested in normal working conditions, generally in accordance with appropriate parts of B.S. 4196 – sound power level of noise sources to meet the requirement of the specification.

## **3. CLEANING, PAINTING AND COLOUR CODING**

### **General**

All equipment and piping or other works installed by the contractor shall be thoroughly cleaned and degreased upon completion of the work.

Painting shall include all piping, fittings, valves, hangers, conduits, framework, ductwork, registers, diffusers, grilles, switchboard, machinery etc. and all work exposed to view. All paint, epoxy / enamels, etc. shall be of approved brand of best quality; readily mixed paint brought in to the site is unopened containers. No painting shall be done in unsuitable weather and all finishing tints shall be as indicated below

or to the approval of the Executive Engineer-CDFD. The contractor shall provide all tarpaulins, sheets and coverings to protect floors, wall etc.

### **Metal Surface**

All metal works shall be thoroughly wire-brushed to remove rust and scale and shall be free from grease. The surface shall then be prepared with an approved rust inhibitive primer and two (2) coats of approved high gloss paint of approved colour as indicated below and to the approval of the Executive Engineer-CDFD.

### **Insulated Surfaces**

Exposed insulated surfaces shall first be sealed with an approved pigmented sealer and painted. One (1) coat of undercoat and two (2) coats of approved high gloss paint to approved colour as indicated below.

### **Pipeline**

Pipeline shall be painted to approve colours, in general, to match surroundings. All the pipes shall be identified to approval by means of circumferential bands of standard colours in accordance with the service. Where lettering is required in addition to colours, the lettering shall be painted in contrasting colours. Letters shall be in the centre of bands and shall be block letters of the following minimum dimension:

Pipe 50mm and under	12mm high
Pipe over 50mm	40mm high

The direction of flow shall be indicated by an arrow painted on the pipe adjacent to each colour band in a contrasting colour. These arrows shall be 80mm long on pipes up to 50mm diameter and 150mm long on pipes over 50mm diameter.

### **Colours of Painting**

Housing, exposed ductwork and insulation	Light Ivory
Chilled Water flow pipes	Blue
Chilled Water return pipes	Light Blue
Registers, diffusers and grilles	To match surroundings
Hangers, supports and conduits	To be correspond to the Services being supported. Common supports to match surroundings

Fans

Jade Green

Generally all pipes shall be colour-coded in accordance with BS1710 and BS4800.

### **Valve Tags**

All valves shall be provided with brass tags or approved equivalent 25mm minimum diameter, with stamped identification numbers on 2mm thick (min) SS / Aluminium plates, secured by chains to each valve handle. Upon completion of the work, drawing and charts showing the location and purpose of each valve shall be prepared. The drawing shall be completed with all valve numbers and shall enable each piping system to be traced by means of the valve tags. The plate size and lettering shall be subject to the approval of the Executive Engineer-CDFD.

### **Name Plates**

Supply and install on each of the following, identification nameplates consisting of a 2mm thick (min) SS / Aluminium plate with engraved lettering. The plate size and lettering shall be subject to the approval of the Executive Engineer-CDFD.

- a) All fans or ventilation units
- b) All starters of fans, pumps, compressors, etc.
- c) Ducting – Each main duct run shall be identified by reference to system and area(s) served.
- d) Control (All control components including thermometer) – Nameplate shall bear the system number and the identification of the control function.

## **4. MEASUREMENTS:**

### **PIPING:**

Shall be measured in units of length along the center line of installed pipes including all pipe fittings, flanges (with gaskets and nuts and bolts for jointing), unions, bends, elbows, tees, concentric and/or eccentric reducers, inspection pieces, expansion loops etc. The above accessories shall be measured as part of piping length along the centerline of installed pipes and no special rates for these accessories shall be permitted. The quoted unit rates for center line linear measurement of piping shall include all wastage, allowances, pipe supports includes hangers, MS channel, PUF/ wooden saddles and its fixing clamps, nuts and check nuts, vibration isolator suspension where specified or required, and cost of excavation, bedding, back filling and finishing as required to complete the piping installation as per the specification.

None of these items will be separately measured and paid for. However, all valves (gate/globe /butterfly /check -balancing/purge/drain etc.), strainers, orifice plates, temperature gauge, pressure gauges shall be separately measured and paid as per their individual unit rates, which shall also include their insulation as per specifications, piping measurements shall be taken before application of the insulation. The cost shall also include any excavations and making masonry valve chamber with steel cover etc.

#### **PIPING INSULATION:**

Shall be measured in units of length along the centerline of the installed pipe, strictly on the same basis as the piping measurements described above. The linear measurements shall be taken before the application of the insulation, it may be noted that for piping measurements, all valves, orifice plates and strainers are separately measurable and their quoted unit rates shall include the insulation cost in the valve required and as specified.

#### **DUCT/ACOUSTIC/UNDERDECK INSULATION:**

This item is provided separately for various thickness and shall be paid for an area basis of un-insulated duct. The area of the duct to be insulated shall be measured before application of insulation. The Under deck insulation shall also be paid on the basis of the area to be covered. This includes the measurement of beam circumference to be insulated.

#### **GRILLS AND DAMPERS:**

These items shall be measured on the basis of physical dimensions of the damper and grills installed at site. The physical measurement shall exclude the flanges on all sides and would be clear inside-to-inside dimension of the damper, grill area.

#### **CABLING/ WIRING/ EARTHING:**

Cabling / earthing shall be measured on the basis of linear measurement from cable termination to cable termination. The cable linear meter shall include necessary brass double compression glands ,Copper / aluminium lugs for crimping and termination, clamps for glands taping, fasteners for supports. The linear meter shall also include the mandatory extra cables to be provided in the panel sides. Measurements will be taken as straight runs along the route. No claims for balance cables remaining after the completion of work will be entertained. No joints in straight runs will be permitted. The contractor has to take the actual measurement of the cable at site along the approved route before procuring cables.

#### **CABLE TRAYS / CONDUITS**

Cable trays shall be measured on the basis of linear measurement. No extra measurement shall be made for bends, offset, tee pieces and other accessories like supports, clamps and grouting anchor fasteners etc. Cable tray shall be mounted as per specification.

<b>PAYMENT TERMS</b>		
Sl No	Details	Description
1	Payment terms	i. 80% on the value of supplied items (This is limited to cost of other than Chiller) ii. 15 % after Installation, Testing and Commissioning of the equipment. iii. 05 % after completion of defects liability period including warranty period. Note: The <b>minimum interim bill</b> amount should be more than <b>Rs 05.00 lacs.</b> <b>INR LC will be opened for 100%.</b>  (85% will be released against the material delivery at Site-CDFD).  Remaining 15% will be released after Installation, Testing and Commissioning of the complete scope of the works. (In Operational Mode).
2	Minimum Billing Period	10 (ten) working days from the date certification from the project consultants subject to its correctness.
3	Performance guarantee (ISD)	2% of the total quoted amount which is inclusive of EMD amount. (Initial Security Deposit -ISD)
4	Total Security Deposit in shape of DD/ BC/ Bank guarantee	5% of the total executed amount in favour of CDFD, Uppal,
5	Defects liability period	12 months from the date of handing over the completed works.
6	Liquidated Damages	At the rate of 0.5% per day delay beyond the agreed completion period subject to a maximum of 5% of the total contract value
7	Validity of the Bid	120 (One hundred and twenty ) days from the last date of submission of the bid.

<b>Approved Makes</b>	
Water Cooled Centrifugal Chiller with Magnetic Bearings	Blue Star/ Carrier/ Trane/ Daikin/ Voltas/ York
Class C MS Pipes	Jindal / Tata
Butterfly Valves	Advance / Emerald / castle / Belimo / Kiz
Ball Valves	RB / Emerald / Audco / Zoloto
Y Strainers	Santh / Emerald / DS Engg
Balancing Valves	Casstle / Advance / T& A / Honeywell
Motorised Butterfly Valves	Advance / Emerald / castle / Belimo / Kiz
Rubber Bellows	Advance / Emerald / castle / Belimo / Kiz
Pressure Guages	H-Guru / Waree / Dwyer / Emerald
Thermometer	H-Guru / Waree / Dwyer / Emerald
Ball Valve for drain	RB / Emerald / Audco / Zoloto
Auto Air Vents	Anergy / RB
Drain Pipe CPVC	Price / Sudhakar / Flowgaurd
MS Structure	Jindal / Tata
Pot Strainer	Jindal / Tata
Piping Valves Insulation	Beardshell /KK Nag
Buried Piping Insulation	Beardshell /KK Nag
Secondary Variable Pumps	Armstrong / Grundfos / Xylem

CDFD - UPPAL, HVAC WORKS SUMMARY				
Sl.No	Work Description	Supply	Instl	Total
		Amount	Amount	Amount
		{A}	{B}	{A} + {B}
A	Chiller - New			
B	Chiller Ancillary			
			Sub Total {Supply + Instlln}	
			GST	
			<b>Grand Total</b>	



SI No	ITEM DESCRIPTION	Unit	Qty	Supply Unit Rate	Total Supply Amount	Inst. Unit Rate	Total Instl. Amount	Total Amount
	<b>SECTION A</b>				{A}		{B}	{A} + {B}
A	<u>WATER COOLED CENTRIFUGAL CHILLER WITH MAGNETIC BEARINGS</u>							
1	Supply, Installation, Testing & Commissioning of Water-cooled Liquid chilling Units complete with Centrifugal compressors - multi stage, water-cooled condenser, evaporator & Unit mounted factory fitted VFD. Below are the brief sepcs of chiller, pls refer the tender specs for detailed specifications							
	The compressor will be a Centrifugal type powered by open/ semi hermetic / fully hermetic electric motor with R-134a Refrigerant and drive motor suitable for 415V +/-15%, 3 phase, 50cps @ 45 deg C drive assembly, guard, etc.							

	<p>Water cooled condenser will be of the shell and tube type 2-pass, designed for 235 psig working pressure on the refrigerant side. Shell will be fabricated from rolled carbon steel plate with fusion welded seams have carbon steel tube sheets, drilled and reamed to accommodate the tubes; and intermediate tube supports spaced no more than four feet apart. Water velocity through the tubes will not exceed 10 fps.</p>							
	<p>Insulation of the chiller using 20mm Armaflex or equivalent insulation and clad with 26 G Aluminum sheets.</p>							
	<p>First charge of R134a refrigerant &amp; oil.</p>							
	<p><b>MOTOR:</b> The compressor motor shall be a hermetic, oil free, permanent magnet type directly coupled to the compressor. The motor will be bolted to a cast iron adapter plate mounted on the compressor to provide factory alignment of the shaft. The motor shaft shall be supported on active magnetic radial and thrust bearings. Magnetic bearing control shall be equipped with auto</p>							

	vibration reduction and balancing systems.							
	Spring type Vibration Isolators as per manufacturer standard supplied from the factory							
	Micro-processor based controls with alpha-numeric display in English for all operating parameters such as supply voltage, frequency, load current, chilled water inlet, chilled water outlet, condenser inlet and outlet temperature parameters, operating pressures, input power etc as per tender specification. The processor must be fitted with card for external communication for parameters in open protocol such as Bacnet/Modbus.							
	Power and control hardware including unit disconnecting / isolating Switch, one point start-stop, protective MCCBs for electric motors, VFD , safety features for under-voltage and over voltage, single phase preventor, trip circuit with sensing elements for HP/LP/Anti-freeze etc.,							

	Victaulic coupling shall be part of the Chiller Package. Painting of all components etc. Price should also includes integral refrigerant piping with liquid isolation valves, and wiring, flow switches / sensors, accessories as required and called for, automatic and safety controls mounted in central control panel and all mounted on a steel frame complete.							
	Min. Actual Capacity 300 TR	Nos	1					
	Entering Chilled Water Temperature = 53.6 deg F							
	Leaving Chilled Water Temperature = 44.6 deg F							
	Fouling Factor for Evaporator SI (FPS) Units = 0.0001							
	Entering Condenser Water Temperature = 86 deg F							
	Leaving Condenser Water Temperature = 95 deg F							
	Fouling Factor for Condenser SI (FPS) Units = 0.0002							
	The Min. COP at 100% capacity = 6.2							
	The Min. COP at IPLV = 11.0							
	Pr. Drop should not be more than 15 feet for both cooler & condenser							

	Imp. Note: Vendor to revalidate the above water in/out at evaporator & condenser side w.r.t the existing conditions. And try to match the same of condenser water temp. for better sizing of the chiller							
	The bidder shall submit a computerized selection sheet of the chiller offered as obtained from the manufacturer along with their offer from the latest AHRI listed software version.							
<b>2</b>	SITCof LOCAL WORKS: for Chiller	Lot	1					
	Disptach from the OEM factory, Transit Insurance to Project site @ Hyderabad.							
	De-stuffing from Container, unloading, lifting with crane & installation of chillers at Plant room (insurance should alive & covered till the Chiller positioned at terrace respective locations as per drg)							
	R134a Refrigerant Charge - Post Installation							
	Oil							
	Vibration isolators for Chiller							
	Harmonic filters - sitc as part of chiller							

	Adaptor Box for the Chiller power cabling terminations.							
	Flow switches for Evaporator.							
	Insulation of Evaporator & Cold parts Nitrile rubber							
	BACnet MSTP/ MODBUS Communication Card							
	Victaulic COUPLINGS							
	Non fused disconnect switch for all the chillers							
	Evaporator shell insulation shall be finished with 24g Al. cladding @ site level once after the testing is done.							
	Supervision of Installation & Commissioning / Testing of chillers.							
	Acoustic Jacketing to be done for the compressors to reduce the noise levels.							
	Note to Bidder: 1. The participants has to visit site and understand the site circumstances / infra / liabilities and accordingly cost for the works involved above.							
	2. The bidders to fill up & to submit the technical data sheets issued as a part of tender submission							

	SUB TOTAL FOR SECTION A							
	SECTION B							
<b>B</b>	<u>PIPING, Valves &amp; Accessories</u>							
<b>1</b>	SITC of MS class `C' pipes confirming to IS 1239 part I & II of 1979 upto date for pipe size upto 150 mm dia and IS 3589 for 200 mm dia pipes and above, minimum thickness of pipes 200 mm dia and above shall be 6 mm, complete with all necessary fittings such as bends, tees, reducers, flanges etc. and supports such as clamps, anti-vibration hangers, PUF saddles etc all pipes fitting/supports shall be painted of approved colour of synthetic enamel paint and direction of flow of fluid in the pipes shall be visibly marked with identifying arrows complete as per specifications & drawings.. Chilled water shall be insulated as per Insul specs.							
<b>1.1</b>	150 mm dia	Rmt	440					
<b>1.2</b>	125 mm dia	Rmt	40					
<b>1.3</b>	100 mm dia	Rmt	RO					
<b>1.4</b>	80 mm dia	Rmt	RO					
<b>1.5</b>	65 mm dia	Rmt	RO					
<b>1.6</b>	50 mm dia	Rmt	30					

<b>1.7</b>	40 mm dia	Rmt	RO					
<b>1.8</b>	32 mm dia	Rmt	60					
<b>1.9</b>	25 mm dia	Rmt	RO					
<b>2</b>	SITC of Butterfly valves with extended neck handle operated duly insulated and complete with companion flanges etc. as specified. Butterfly valves PN16 shall be designed to fit without gaskets between mating flanges. The valves shall be suitable for flow in either direction and seal in both directions. The valves shall be of integral moulded design. MOC & other specs refer tender specs. Valves shall be insulated with the same material and finish that of chilled water piping							
<b>2.1</b>	150 mm	Nos	6					
<b>2.2</b>	125 mm	Nos	4					
<b>2.3</b>	100 mm	Nos	RO					
<b>2.4</b>	80 mm	Nos	RO					
<b>2.5</b>	65 mm	Nos	RO					
<b>2.6</b>	50 mm	Nos	3					
<b>3</b>	SITC of Ball valves (FOR CHW Units) with Insulation, Threaded Conn, one side flange set, bolt & nuts, etc. Valves shall be insulated with the same material and finish							



	that of chilled water piping. Valves shall be of PN 16 rating. MOC & other details refer tender specs							
<b>3.1</b>	40 mm	Nos	RO					
<b>3.2</b>	32 mm	Nos	RO					
<b>3.3</b>	25 mm	Nos	RO					
<b>4</b>	SITC of Y Strainers PN16 with insulation, flanges, permanent plug, bronze strainer, etc. Valves shall be insulated with the same material and finish that of chilled water piping. MOC and other details refer tender specs							
<b>4.1</b>	125 mm dia	Nos	RO					
<b>4.2</b>	100 mm dia	Nos	RO					
<b>4.3</b>	80 mm dia	Nos	RO					
<b>4.4</b>	65 mm dia	Nos	RO					
<b>5</b>	SITC of Semi Auto Balancing Valve with Insulation, Flanges, provision to measure the pressure drop for balancing, etc. Water balancing shall be done by the supplier of the manual balancing valves. MOC and other details refer tender specs., Valves shall be insulated with the same material and finish that of chilled water piping.							

<b>5.1</b>	150 mm dia	Nos	1					
<b>5.2</b>	125 mm dia	Nos	2					
<b>5.3</b>	125 mm dia	Nos	2					
<b>5.4</b>	80 mm dia	Nos	RO					
<b>5.5</b>	65 mm dia	Nos	RO					
<b>6</b>	SITC of Motorized Butterfly valves with Actuator torque suitable with extended neck handle operated duly insulated and complete with companion flanges etc. as specified. Butterfly valves PN16 shall be designed to fit without gaskets between mating flanges. The valves shall be suitable for flow in either direction and seal in both directions. The valves shall be of integral moulded design. MOC & other specs refer tender specs. Valves shall be insulated with the same material and finish that of chilled water piping							
<b>6.1</b>	150 mm	Nos	RO					
<b>6.2</b>	125 mm	Nos	2					
<b>6.3</b>	100 mm	Nos	RO					
<b>7</b>	SITC of Rubber Bellows complete with companion flanges etc. as specified. PN16 shall be designed to fit without gaskets between							

	mating flanges. The valves shall be suitable for flow in either direction and seal in both directions.							
<b>7.1</b>	150 mm	Nos	RO					
<b>7.2</b>	125 mm	Nos	4					
<b>7.3</b>	100 mm	Nos	RO					
<b>8</b>	SITC of 100 mm dia dial type pressure gauges with ball / needle valve	Nos	6					
<b>9</b>	SITC of 100 mm dia thermometer with thermo well. Pipe size shall be increased locally to install the thermometer.	Nos	6					
<b>10</b>	SITC of Ball valve for drain with, nipple, dummy, etc.							
<b>10</b>	32 mm dia	Nos	8					
<b>10</b>	25 mm dia	Nos	RO					
<b>11</b>	SITC of Auto Air Vents with isolation ball valve of 20 mm dia.	Nos	6					
<b>12</b>	SITC of Drain piping CPVC HDR 13.5 with 6 mm thick Closed cell foam insulation (40 kg/m <sup>3</sup> density) & all fittings, supports and clamps up to 80 mm dia. (all Floor Drain piping shall be runs up shaft riser							

	& get connected to the shaft riser which will be provided by others), Proper slope to be maintained towards shaft pipe to maintain natural gravity flow. all fittings and supports are included. support to be provided @ every 1.5 Mtr							
<b>12</b>	25 mm dia	Rmt	RO					
<b>12</b>	32 mm dia	Rmt	RO					
<b>12</b>	40 mm dia	Rmt	RO					
<b>12</b>	50 mm dia	Rmt	RO					
<b>13</b>	SITC of Structural MS steel for supporting & base frame structures for piping above ground supports shall be duly painted. This covers angles, chanel, plates & supports inside shafts and open piping support ducts and pipes. Required sizing of the support and approvals to be taken from the client before works commencement.	Kgs	2000					
<b>13</b>	SITC of RCC Blocks / Bed for the piping supports to be considered for above piping supports. Required sizing of the support and approvals to be taken from the client before works commencement. Each support should have these RCC bed	Lot	1					

	provided at an intervals of 3 Mtr or less as per site feasibility.							
<b>14</b>	SITC of Dia 200 mm Pot Strainer PN 16 for the condenser water header system pl. refer specs for the details	Nos	RO					
<b>E</b>	<u>INSULATION:</u>							
	<u>INSULATION FOR PIPING &amp; VALVES</u>							
<b>1</b>	For OVERHEAD PIPING / VALVES Insulation & Finishing: post 2 coats of zincromite anti corrosive resistant paint shall be applied, 85/25 adhesive shall be applied on both the surfaces (pipe & the pipe insul.) and should wrap with the glasscloth with star bond adhesive & finished with 24G AL sheet.  The quantity of insulation per valve will be taken as 2 rmt of pipe of the same size and will be measured with piping qty							
	Insulation Thick: Pipe Dia: up to 65mm Dia - 50MM thic EPS sections 50 to 200mm Dia - 100 MM EPS							

	sections. Refer the Tender Specs for details and specifications							
<b>1.1</b>	150 mm dia	Rmt	440					
<b>1.2</b>	125 mm dia	Rmt	40					
<b>1.3</b>	100 mm dia	Rmt	RO					
<b>1.4</b>	80 mm dia	Rmt	RO					
	Each valve shall be considered as 2m of conn Pipe length and included in pipe measurement							
<b>2</b>	For Trench / Buried Piping Insulation & Finishing: post 2 coats of zincromite anti corrosive resistant paint shall be applied, 85/25 adhesive shall be applied on both the surfaces and fix the pre formed EPS sections of 100mm thick pipe section insulation, finished with 500 micron polythene/ covered with 3/4 inch * 24g chicken wire mesh and finished with 2 coats of 12mm thick sand cement plaster finishing							
	150 mm dia	Rmt	RO					
	125 mm Dia	Rmt	RO					
<b>3</b>	SITC of FRP 2 mm Coat lining for the exposed valves / CNDS pipes / air seperators / strainers / pot	Lot	1					

	strainer and Etc., post installation of HVAC services							
<b>4</b>	Testing, Balancing & Commissioning of CHW pipe lines., Designed Flow and Temp shall be recorded and shown to the project team for approvals. All instrumentations shall be high accurate measuring type & with valid calibration certificates.	Lot	1					
<b>5</b>	<p>Removal: Disconnect and detach the existing 300 TR water-cooled chiller from its current location.</p> <p>Lifting: Safely lift the chiller using appropriate equipment, ensuring no damage occurs to the chiller or surrounding areas.</p> <p>Shifting: Transport the chiller to the designated location specified by CDFC.</p> <p>Placement: Carefully position the chiller at the CDFC designated location.</p> <p>Piping: Terminate all necessary piping connections, including valves and blanking off any open connections.</p> <p>This entire process, including the safe removal, lifting, shifting, and placement of the chiller, as well as</p>	Lot	1					

	the required piping terminations, valves, and blanking off of piping connections, should be included in this line item.							
<b>6</b>	<p><b>FUTURE TAPPINGS:</b> This task involves modifying the existing chilled water (CHW) system. The existing CHW piping will be isolated, and the water drained from the section where the new tap-off will be installed., the Tap-off Point exact location of the tap-off point will be determined on-site, based on the provided drawings. CDFD team approval must be obtained before proceeding.</p> <p><b>Install Tap-off:</b> The tap-off will be installed, including all necessary valve sets. the finishes should be good post inculation of the piping and should match to the existing finishes as match as possible.</p> <p><b>Pressure Test:</b> After installation,</p>	Lot	1					



	<p>the vendor will pressure test the new connection by filling the isolated section with water and checking for leaks. If the test is successful, the vendor will proceed to the next step.</p> <p>System Balancing: Following successful pressure testing, the vendor will balance the CHW system</p>							
	<b>SUB TOTAL FOR SECTION B</b>							
	<b>SUB TOTAL {SECTION A + SECTION B}</b>							
	<b>GST</b>							
	<b>GRAND TOTAL</b>							

TECHNICAL DATA SHEET		
Data must be furnished by tenderer along with offer complete with Annex- 1A		
Description		
<b>Water / Air Cooled Chilling Machine Equipment</b>	Units	
<b>Unit information / Make</b>		
Country of Origin		
Model No.		
Nominal Cooling Capacity – at AHRI condition	TR/ KW	
No. of compressors per machine (Minimum-2)	Nos	
Leaving Water Temperature	°C / °F	
Operating Condensing Temperature	°C / °F	
Compressor Suction Temperature	°C / °F	
Capacity at Design Operating Conditions	TR / KW	
Overall Dimension – L x W x H	Mt	
Overall Weight	Kg	
Operating Refrigerant Charge	Kg	
Noise Level at 1.0 Metre from the Unit	dB	
Compressor(s)		
Compressor Type:		
Construction (hermetic/semi hermetic)		
Manufacturer's Name and Model		
Refrigerant		
Cylinder/Screw data		
Speeds (Operating/Max.)	RPM	
Operating condensing and suction temperatures	°C / °F	
Capacity at Design conditions	TR/kw	
KW at operating conditions	KW	
Motor losses	%	
Other losses if any	%	
Motor intake power	Kw	
KW per TR at operating conditions 100%	KW/TR	
Capacity control – Range	%	
No. of steps of capacity control		
Capacities and COP & KW/TR as per ARI condition	COP	IKW/ TR
At 100% Capacity or Loading Condition		
At IPLV Condition		
At NPLV (Refer detail sheet as attached & fill up chart at part load & various outdoor conditions)		
Min COP at AHRI condition at full load as per leed		
Motors		
Manufacturer's Name		
Motor KW	KW	
Rated current	Amps	
Motor efficiency	%	
Starting current with type of starter offered	Amps	
Model / Frame size		
Starter (VFD)		
Type	VFD	
Make		
Model no.		
Quantity- Nos.		
VFD Rating - Kw.		
Rated Current - Amps.		
Maximum Output - Kw.		
PID Controller provided (Yes / No)		
Interface with BAS		
Fault Indication		
Dimension (mm)		
No. of Steps		
Operating Weight-(Static)-Kg		
Communication Protocol		
Whether single phasing preventer included		
Whether over load relay included		
Drive		
Type of drive		
Any special requirements		

<b>Condensers (Air-Cooled / Water Cooled)</b>		
Manufacturer's Name		
Dimensions – L x B x H mm or Dia x Length	MM	
Fan Motor ratings	kW	
Fan Noise level	dB	
No of Fans per Chiller	Nos	
Discharge temperature - °C	°C / °F	
No. of fins / inch in the Condenser coil	fns/inch	
Minimum condenser water flow rate	CMH / USGPM	
Maximum pressure drop through Condenser	MWC / FTWC	
Entering condenser water temperature	°C / °F	
Leaving condenser water temperature	°C / °F	
Fouling factor for condenser		
<b>Evaporator or Cooler</b>		
Type of Chiller (DX or flooded)		
Shell OD – mm	MM	
Overall length – mm	MM	
Overall weight – Kg.	Kg	
No. of tubes	Nos	
Tube OD – mm	MM	
Nature of tubes (whether integrally finned or tubes carry inserts)		
Length of tube between tube sheets - mm	MM	
Material of tube		
Material of shell		
Water side surface area .	Sq.Mt.	
Refrigerant side surface area	Sq.Mt	
Flow rate – Lpm / Gpm	LPM/GPM	
Entering water temperature	°C / °F	
Refrigerant temperature	°C / °F	
Temperature difference	°C / °F	
No. of passes	Nos	
Tube velocity	MPS/FPS	
Pressure drop – Water column	Ft. / Mt	
CPM		
Type		
Make		
Model no.		
Units Communication		
ON/OFF COMMAND		
GROUP SEQUENCING MANAGEMENT		
WEEKLY/HOURLY CHILLER ROTATION		
CRITICAL FAULTS		
ALARMS		

**CDFD HIGH SIDE CHILLED WATER SCHEMATIC DIAGRAM.**

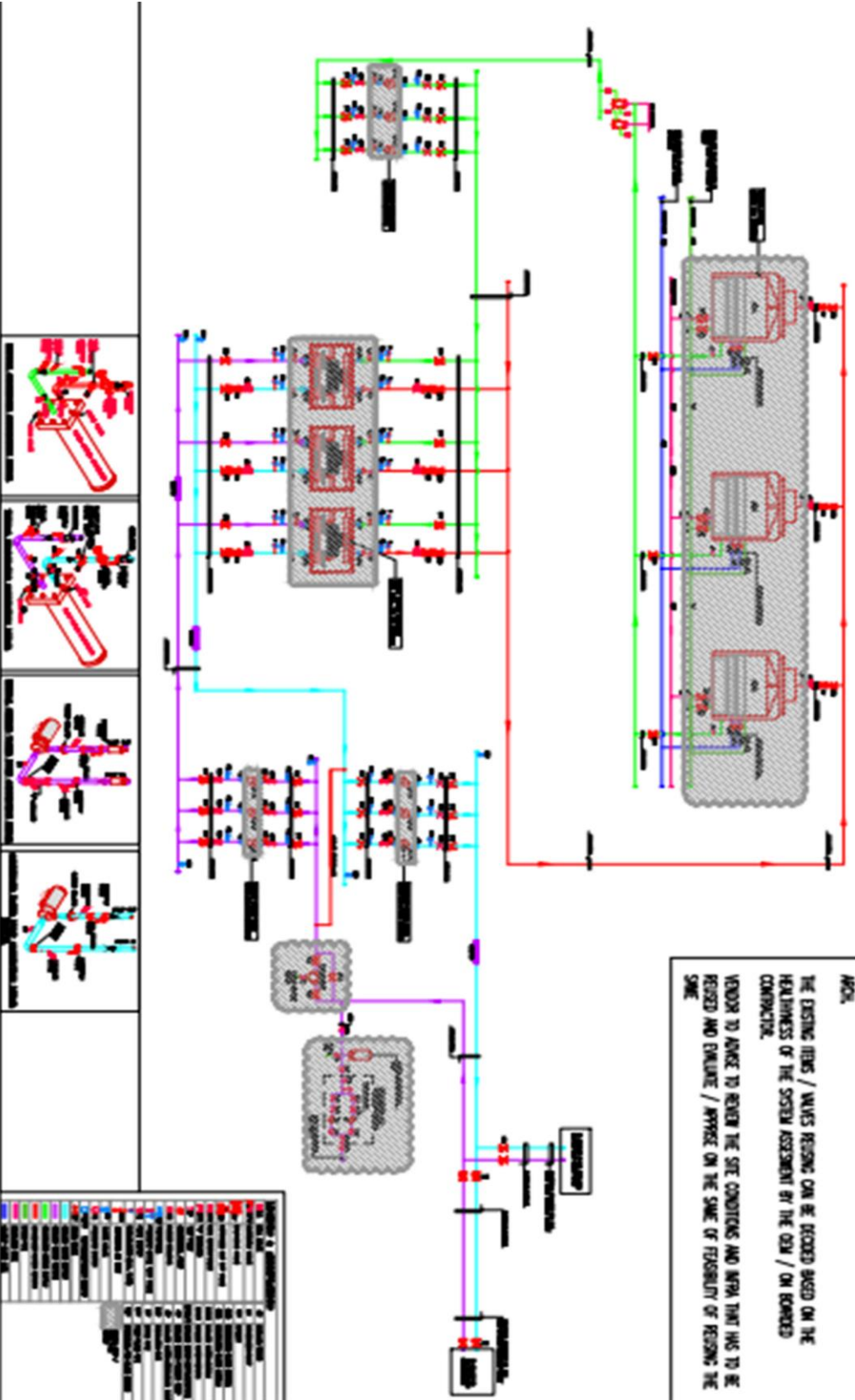

**NOTES**  
 THE ITEMS MENTIONED HERE ARE AS PER THE EXISTING SCHEME. THIS MAY BE  
 REVIEWED / CHANGED ACCT THE SITE CONDITIONS TO SUIT TO THE REQUIREMENTS.  
 HENCE THIS CAN BE A REFERRAL AND UNDERSTANDING. ICC FOR WHOLESTLY SYSTEM  
 APPLICABLE.  
 THE EXISTING ITEMS / VALUES MENTIONED CAN BE DECIDED BASED ON THE  
 HEALTHINESS OF THE SYSTEM ASSESSMENT BY THE O&M / ON BOARD  
 CONTRACTOR.  
 VENDOR TO ADVISE TO REVIEW THE SITE CONDITIONS AND MATERIAL THAT HAS TO BE  
 REVISIT AND EVALUATE / REVISE ON THE SAME OF FEASIBILITY OF REVISION THE  
 SAME.

ITEM NO.	DESCRIPTION	UNIT	QTY	REMARKS
1	CHILLER	HP	3	
2	CONDENSATE TANK	LITRE	1	
3	CONDENSATE PUMP	HP	1	
4	RETURN TANK	LITRE	1	
5	CONDENSATE PUMP	HP	1	
6	CONDENSATE PUMP	HP	1	
7	CONDENSATE PUMP	HP	1	
8	CONDENSATE PUMP	HP	1	
9	CONDENSATE PUMP	HP	1	
10	CONDENSATE PUMP	HP	1	
11	CONDENSATE PUMP	HP	1	
12	CONDENSATE PUMP	HP	1	
13	CONDENSATE PUMP	HP	1	
14	CONDENSATE PUMP	HP	1	
15	CONDENSATE PUMP	HP	1	
16	CONDENSATE PUMP	HP	1	
17	CONDENSATE PUMP	HP	1	
18	CONDENSATE PUMP	HP	1	
19	CONDENSATE PUMP	HP	1	
20	CONDENSATE PUMP	HP	1	
21	CONDENSATE PUMP	HP	1	
22	CONDENSATE PUMP	HP	1	
23	CONDENSATE PUMP	HP	1	
24	CONDENSATE PUMP	HP	1	
25	CONDENSATE PUMP	HP	1	
26	CONDENSATE PUMP	HP	1	
27	CONDENSATE PUMP	HP	1	
28	CONDENSATE PUMP	HP	1	
29	CONDENSATE PUMP	HP	1	
30	CONDENSATE PUMP	HP	1	
31	CONDENSATE PUMP	HP	1	
32	CONDENSATE PUMP	HP	1	
33	CONDENSATE PUMP	HP	1	
34	CONDENSATE PUMP	HP	1	
35	CONDENSATE PUMP	HP	1	
36	CONDENSATE PUMP	HP	1	
37	CONDENSATE PUMP	HP	1	
38	CONDENSATE PUMP	HP	1	
39	CONDENSATE PUMP	HP	1	
40	CONDENSATE PUMP	HP	1	
41	CONDENSATE PUMP	HP	1	
42	CONDENSATE PUMP	HP	1	
43	CONDENSATE PUMP	HP	1	
44	CONDENSATE PUMP	HP	1	
45	CONDENSATE PUMP	HP	1	
46	CONDENSATE PUMP	HP	1	
47	CONDENSATE PUMP	HP	1	
48	CONDENSATE PUMP	HP	1	
49	CONDENSATE PUMP	HP	1	
50	CONDENSATE PUMP	HP	1	

